



Xtreme XM Series Friction Feeders

**Operation Instructions, Technical Guide,
And Parts List Information**



For Models:

Xtreme XM-1 Versatile Friction Feeder
Xtreme XM-20 Versatile Friction Feeder

Have this information ready when calling in about your equipment:

Model: _____ Serial #: _____ Circuit Board #: _____
Warranty Start Date: _____

Model: _____ Serial #: _____ Circuit Board #: _____
Warranty Start Date: _____

Model: _____ Serial #: _____ Circuit Board #: _____
Warranty Start Date: _____

Model: _____ Serial #: _____ Circuit Board #: _____
Warranty Start Date: _____

© Superior Paper Handling Solutions, Inc. All rights reserved.

Illustrations in this guide are for reference only and may depict optional features that are available at additional costs.

Superior Paper Handling Solutions, Inc.
7150 Boone Ave N., Suite 130
Brooklyn Park, Minnesota – USA

Tel. 763-546-9140
Fax. 763-546-8883
Email. info@Superior-PHS.com
Web. www.Superior-PHS.com

Table of Contents

- SECTION 1: MACHINE OVERVIEW6**
- SECTION 2: SETUP.....6**
 - Separator Setup7
 - Hopper Setup8
 - Wedge Assembly Setup9
 - Discharge Hold-Down Setup.....10
 - Sheet Sensor Photo Eye11
 - OPTIONAL: Electro-Mechanical Double Sheet Detector Setup.....12
- SECTION 3: OPERATION13**
 - Apply Power.....13
 - Trigger Sensor.....13
 - Loading Product.....14
 - Front Control Panel Features.....15
 - Jog Button*.....15
 - Reset Button*.....15
 - Ready Mode*15
 - Stop Mode*.....15
 - Batch Size Thumb Wheels*.....15
 - Main Speed Dial*.....16
 - Trigger Delay Dial*.....16
 - End-of-Batch Speed Change*16
 - Shutdown*16
 - Rear Control Panel Features17
 - Time-Out*17
 - Miss Detect*.....17
 - Double Detect*.....17
 - Vacuum Belt and Manifold17
 - Trigger Delay Timing Reference18
 - Additional Set-Up Information.....19
 - Different Variables of Feeding Product*19
 - Repositioning the Separating Rollers*19
 - Rotating Gate*20

SECTION 4: WIRING AND ELECTRICAL DETAIL.....21

SECTION 5: COMPONENTS / PARTS LIST27

Carriage Assembly28

XM-20v Carriage.....30

Chassis Components31

Hopper Assembly.....32

Separator Assembly33

Hold Down Assembly (3-piece design)35

Wedge Assembly36

Sheet Sensor Assembly37

Trigger Sensor Assembly38

Front Control Panel39

Rear Control Panel.....40

SECTION 6: ACCESSORIES AND AFTERMARKET OPTIONS41

SECTION 7: MAINTENANCE46

Belts46

Sensors46

Machine.....46

Separator Assembly Removed from Feeder46

How to Change Xtreme XM Feeder Belts.....47

SECTION 8: OPERATIONAL TROUBLESHOOTING49

SECTION 9: GLOSSARY OF TERMS50

SECTION 10: WARRANTY53

SECTION 1: MACHINE OVERVIEW

Please review the components and descriptions to become familiarized with your new Xtreme XM-1 Versatile Friction Feeder.

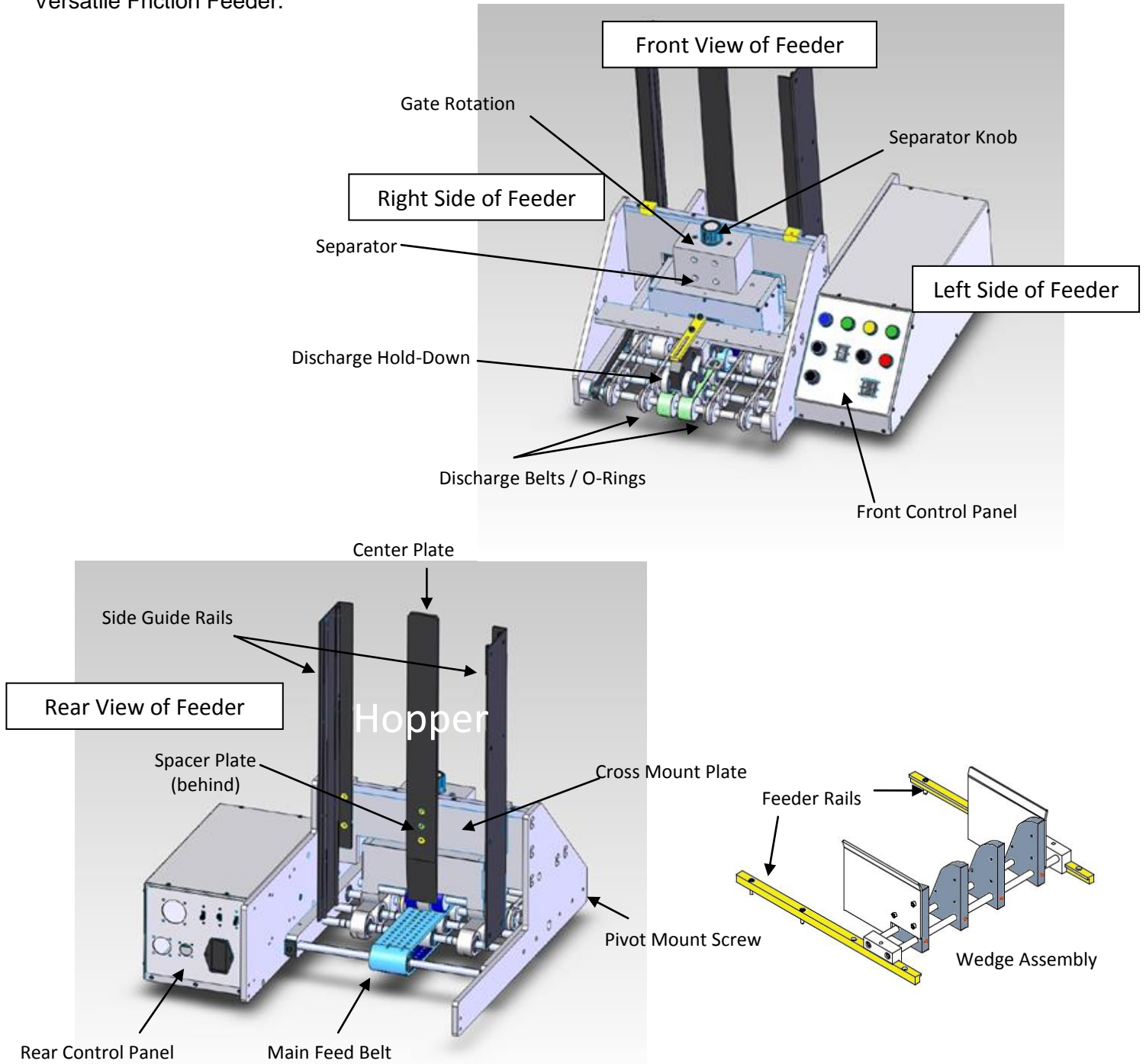

SECTION 2: SETUP

This section will walk you through setup adjustments for the *Xtreme* XM-1 Versatile Friction Feeder. Refer to the Basic Setup Guide for assembling your feeder when shipped from the manufacturer.

For a video demonstration of basic feeder setups, visit

<http://www.superior-phs.com/setup.html>

Take a moment to get familiarized with the basic feeder components on the previous page. Basic feeder setup consists of three main components: the Separator, the Hopper & Wedge Assembly, and the Discharge Hold-Down. **Power to the feeder should remain off** during the Separator and Hopper & Wedge Assembly setup.

***** Never Plug-In or Unplug Any Wires, Cables, or Electrical Components on the Feeder Without First Powering Down the Feeder and Removing All Power*****

Separator Setup

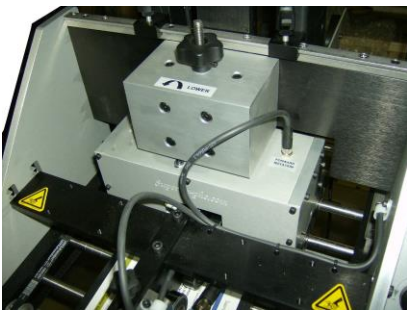

Figure 2.1

The Separator (Figure 2.1) is the device that separates product from the stack in the Hopper. Turning the knob clockwise will increase the gap between the gate assembly and the main feed belt; counter-clockwise will decrease the gap. This will create drag on the product and separation as product is pulled through the feeder.



Figure 2.2

Raise the Separator and advance one piece of product underneath the Gate Rollers (Figure 2.2). Slide the piece forward and backward while turning the separator knob counter-clockwise (Figure 2.3) to create a medium drag on the piece.

Make certain that the drag is not too tight or too loose. If the drag is too tight, the rollers may “mark” some products or prevent products from advancing causing miss-feeds. If the drag is too loose, the rollers will allow extra products to advance at the same time causing double feeds.



Figure 2.3

The Separator is equipped with a gear motor that automatically rotates the Gate Rollers as the feeder is running. For most products, it does *not* matter which direction the Gate Rollers turn – forward or reverse. In fact, you can unplug the gate power cable so the Gate Rollers are not turning and the feeder will still function properly.

NOTE: Always power off the feeder *before* removing power to the Separator.

For more information on selecting gate rotation, see Section 3: Additional Setup Information.

Hopper Setup



Figure 2.4

The hopper consists of a cross mount plate, center plate, two side guides, side guide clamps, and handles shown in Figure 2.4 (See exploded view under Hopper Assembly). The side guides are adjustable side-to-side to allow for different product widths. The feeder comes with two rods for each side guide. Each side guide has two rods that can be installed to reduce drag, reduce pinch-points, and reduce possible marking. The rods can be adjusted up and down to assist in skew control (Figure 2.5). Using the rods depend on the type of product being ran.

NOTE:

BE SURE THAT THE RODS DO NOT CONTACT THE BELTS

Load one piece of product in the center of the hopper and adjust the side guides up to the edge of the product. Proper setup allows approximately 1/16" to 1/8" clearance from the side guides to the product.

For product thicknesses of 1/4" and under, the hopper assembly should be mounted in the lower slot of the "E" mount of the feeder's left and right side plate (Figure 2.6). For thicker products, loosen the fasteners and slide the assembly up (1/4"-1/2" and 1/2"-3/4"). *Note:* You will need to perform the same operation on the hold down assembly.

For products 3.25" wide up to 12" wide, loosen the lever handles and manually slide the side guide(s) to the desired position. Tighten the lever handle(s) when completed.

For products 2" wide up to 3.25" wide, "flip-flop" the two side guides (Figure 2.7) so that the smooth side of the side guides are now on the inside. This is done by removing the screws that fasten the side guides to the side guide clamps. Swap the side guides and refasten using the same screws.



Figure 2.5

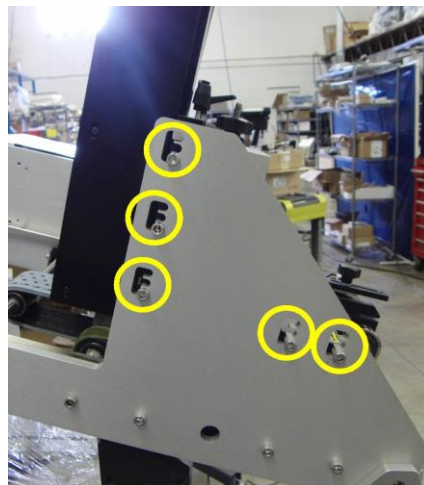

Figure 2.6



Figure 2.7

Wedge Assembly Setup

Figure 2.7



Figure 2.8

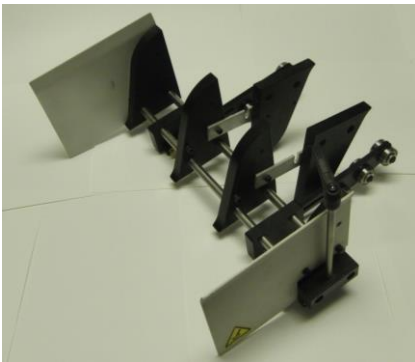
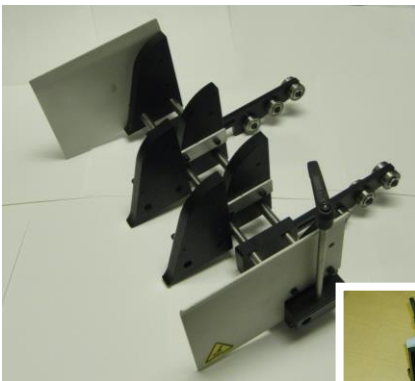

Figure 2.9



The Wedge Assembly provides “lift” to the rear of the product in the hopper. The amount of lift and wedge configuration will depend on the type of product. Typically, products that are rigid need less lift/support than products with less rigidity. Adjustment of the wedge will, in part, determine the amount of overlap of the products as they pass through the Gate Rollers.

If the Wedge Assembly is not attached to the feeder, slide the entire Wedge Assembly over the Feeder Rails in the Hopper and tighten down with the two knobs included. To adjust the wedge support, loosen the knob on either side of the Wedge Assembly and slide the assembly forward or backward. A good starting point is a lift angle of approximately 20-degrees on the first piece (Figure 2.10) Depending on your product, you may need to increase or decrease this angle once more product is loaded and you have test run a few cycles. Next, slide the black wedge blocks side-to-side to accommodate the width of your product.

The Xtreme XM Wedge Assembly comes standard with Small Product Wedges and Wedge Support Rollers.

Wedge Selection:

Products <4”L: See Figure 2.9

Products >4”L: See Figure 2.8

Products >7”L:

Not Rigid (i.e. thin sheets): See Figure 2.7

Ridge (i.e. chipboard): See Figure 2.8

The Roller Support Wedges fasten directly to the two drop blocks on the Standard Wedge shafts using four thumbscrews. They are adjustable in and out to provide more or less lift to flimsy stocks.

Included in this assembly are two Wedge Side Guides to assist in containing the product and preventing “skew”. Some wider product sizes will rely solely on the Wedge Side Guides and the Hopper Side Guides can be set to the most outward position in the hopper.

The Small Product Wedges and Wedge Support Rollers have a mounting feature design that allows them to be rolled backward when not in use. See Figure 2.9



Figure 2.10

Wedge Assembly Setup Continued...

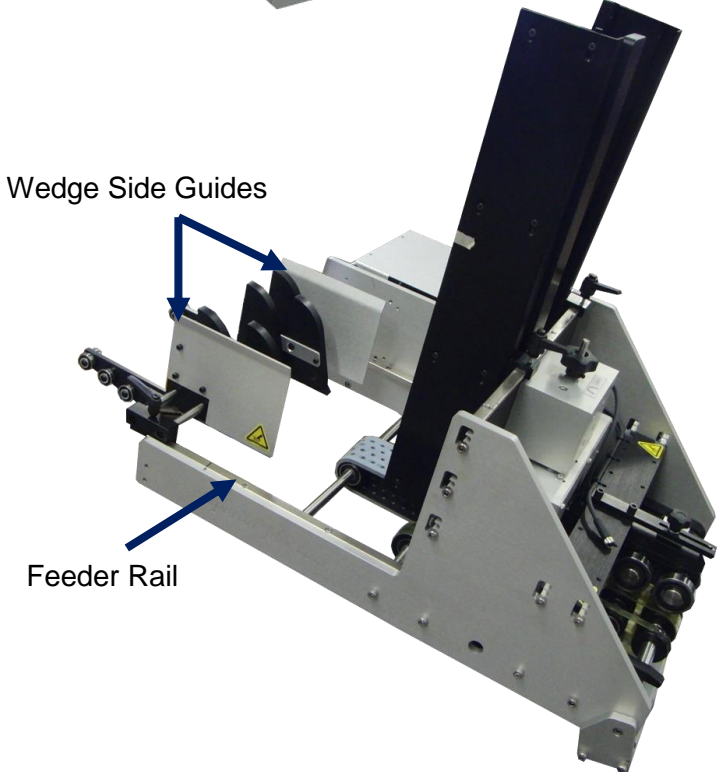
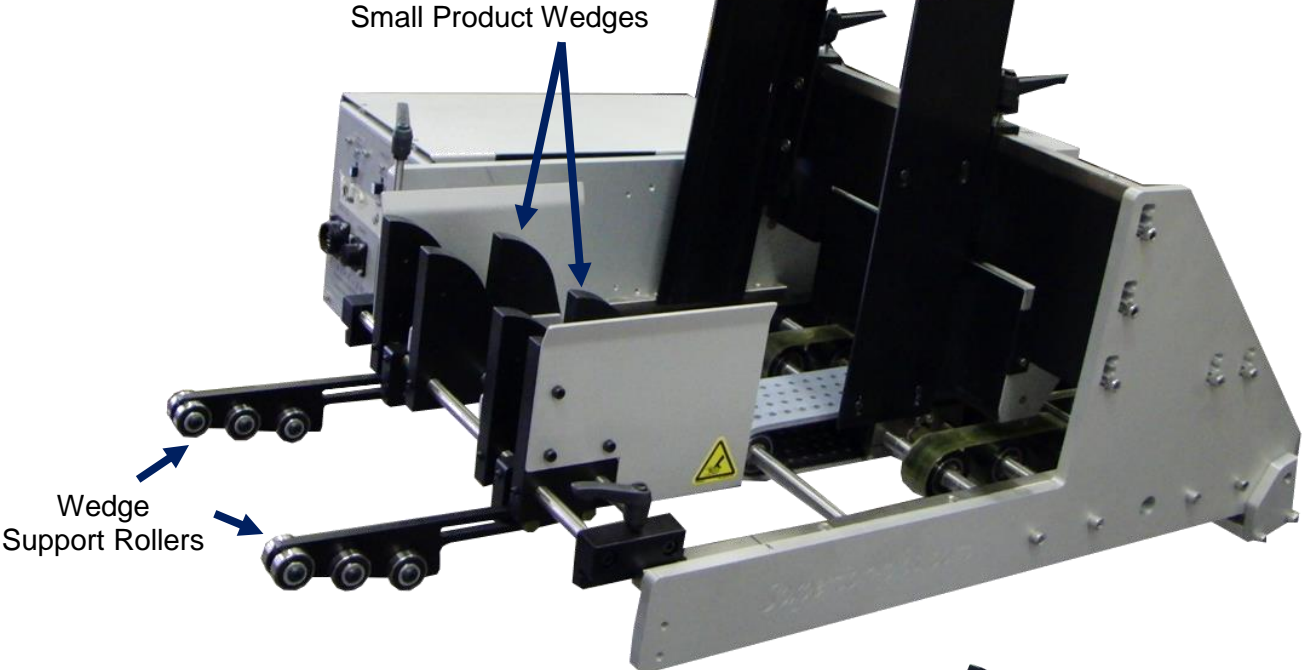

Discharge Hold-Down Setup

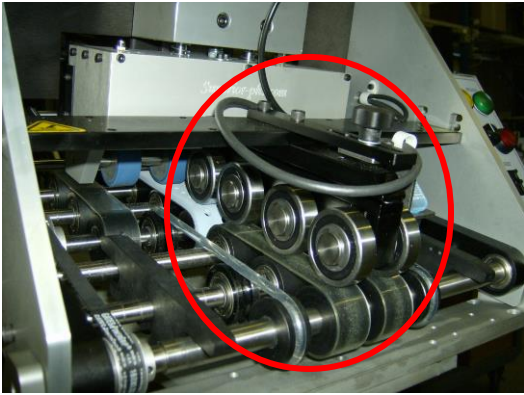

Figure 3.1

The Discharge Hold-Down (Figure 3.1) is designed to assist in accelerating the product to create a gap between them. This assembly consists of self-adjusting spring loaded wheels and two fine-tuning adjustment screws.

The fine-tuning adjustment screws allow for more or less tension to be applied to the product as it passes through the discharge of the feeder. The rear adjusting screw is located just behind the cross bar and the front one is located through the opening on the sensor mount bracket.

To set the Hold-Down, power on the feeder and slowly press the Jog button to jog one piece of product through the feeder until it rests under the Hold-Down. By hand, move the product back and forth under the Hold-Down while adjusting the adjustment screws with a 3/8" allen wrench until there is a good amount of drag on either end of the Hold-Down (Figures 3.2 and 3.3). For products such as corrugate, minimal drag is needed.

Figure 3.2

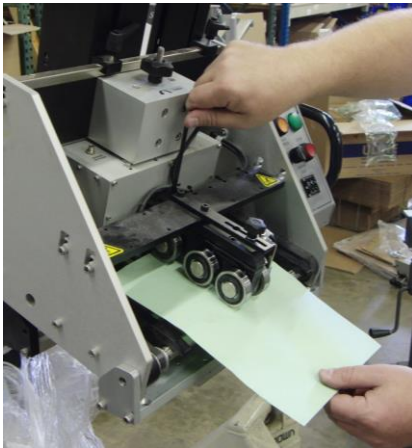
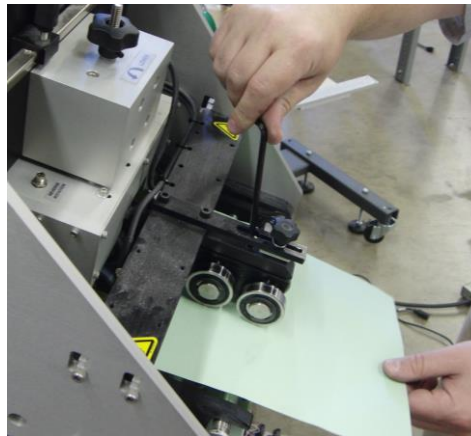

Figure 3.3



Sheet Sensor Photo Eye

The Sheet Sensor Photo Eye is used to detect the leading edge of a piece of product as it exits the feeder. Position the sensor at the discharge of the feeder where you want your product to stop. Be sure not to position the Sheet Sensor over a shaft or other obstruction. This will cause inaccurate counts.

Note: The Sheet Sensor must detect a gap between each product in order to maintain accurate counts. This is indicated by the light going on and off. A gap of 1" or more as product passes the Sheet Sensor is recommended.

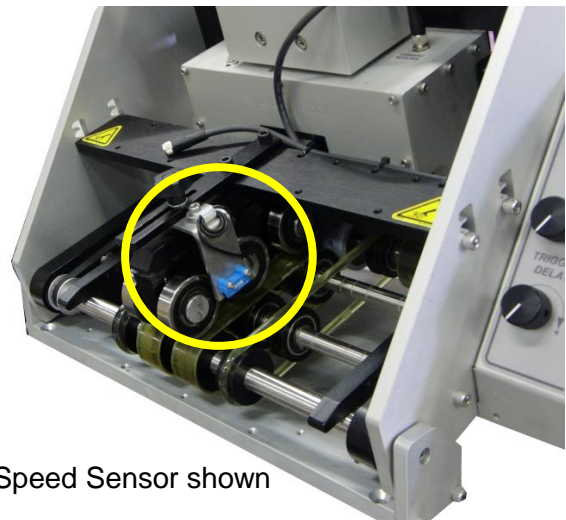

High-Speed Sensor shown

OPTIONAL: Electro-Mechanical Double Sheet Detector Setup

NOTE: This is not a standard operating feature on the XM-1. You can skip this setup step if you did not purchase this feature separately.

Operation and Setup:

The electro-mechanical double sheet detector is a Proximity Sensor mounted above the last discharge roller. When this sensor is activated (sensing a double), and the Double Detect routine is enabled (switch on rear of panel), the feeder will stop and illuminate the Reset lamp with a slow blink. To reset, simply remove the product from under the discharge roller and press the Reset button. Press the Cycle button once to stage a new piece to the sheet detect sensor.

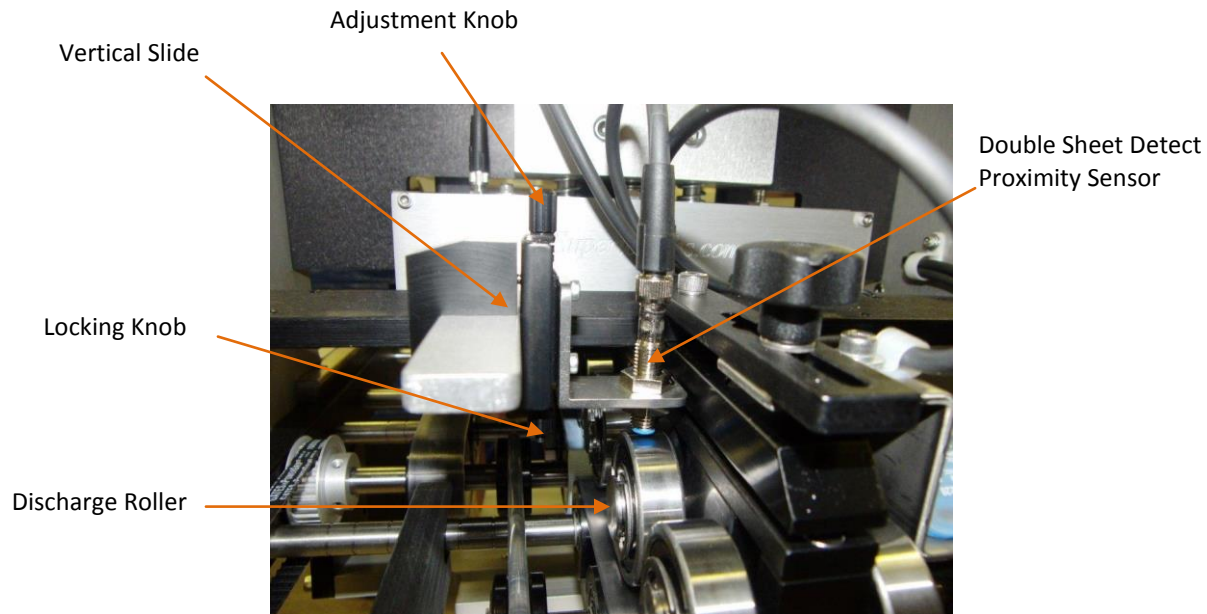

Setup – To adjust the proximity sensor, advance 2 pieces under the discharge roller below the prox sensor. Loosen the bottom locking knob on the vertical slide. Loosen or tighten the top adjustment knob on the vertical slide to move the prox sensor up or down.

Adjust the position so that you are just detecting the double and tighten the bottom locking knob. If the position is too far into the detection range, false triggers may occur from the bounce of the roller under normal operation. Next, remove one of the pieces of product and make certain that the prox sensor is not detecting a single.

Once satisfied, cycle a few pieces through the feeder to insure that singles do not trip the prox sensor.

Please note that for operation, you will need to “Enable” this feature by moving the slide switch for the Double Detect to the Enable position. The switch is located on the rear interface panel.

SECTION 3: OPERATION

***Before Powering on the Feeder:

If you are using the Trigger Sensor assembly provided (or any external I/O interface cable) to automatically cycle the feeder, plug-in the Trigger Sensor located in the Rear Control Panel and mount it directly to the feeder near the discharge or near the equipment that will be triggering the sensor, such as a conveyor. **DO NOT PLUG OR UNPLUG POWER TO THE TRIGGER SENSOR OR EXTERNAL INTERFACE CABLE AT ANYTIME WITHOUT FIRST POWERING DOWN THE FEEDER.**

FAILURE TO DO SO CAN RESULT IN DAMAGE TO THE CONTROLS INTERFACE ON THE CIRCUIT BOARD.

Apply Power

1. It is important to make sure that you are applying the correct voltage to the unit. At the Rear Control Panel the display will state 115v or 230v. You must only supply the power to the unit as stated on the module. A power supply will be provided with your feeder.
2. Once you have applied power, switch the unit to the “On” position (-) by pressing the on/off switch located on the Rear Control Panel.
3. The feeder will perform a self-check indicated by the “Reset” “Ready” and “Stop” buttons flashing once then the “Reset” light staying on. This indicates the feeder is in Setup Mode.
4. Press the “Reset” button and the “Ready” button will light up green indicating the feeder is in Ready Mode and is ready to receive a trigger signal from the Trigger Sensor or by manually cycling the feeder by pushing the green “Manual Cycle” button.
5. To start, make sure your Main Speed is set at 1/3 or 10 o'clock. Set the End-of-Batch Speed Change thumbwheel to “0”. Set the Trigger Delay dial all the way counter-clockwise past the “-” sign.

Trigger Sensor



Trigger Signal

The trigger signal is what initiates the feed cycle. This signal is received by either the Trigger Sensor or by manually cycling the feeder. When received, this puts the feeder into motion and dispenses product(s). The number of pieces that will be dispensed is determined by the number you preset on the batch-size thumbwheels. *Note:* If more than one trigger signal is received prior to completion of the feed cycle, a “Miss-Feed” will be detected (see the glossary for more information regarding miss-feed).

Loading Product

1. Load one piece of product in the Hopper as described in the Hopper Setup section. To start, this piece of product should be resting on the Wedges with approximately 20 degrees of lift.
2. Pre-shingle, or fan out, a 1" stack of product (pictured top-right) and load into the hopper resting under the gate rollers (pictured bottom right). Make sure to maintain the pre-shingle effect so it matches that of the lead-in plate on the Separator.
3. Repeat Step 2 with another 1" stack until you have approximately 3" to 4" of product in the Hopper. All of the product in the Hopper should be evenly fanned out along the Wedges with no random pieces sticking out. This initial setup of product is very important to maintain even feeding as you continue to load the Hopper.
4. Press or hold down the Jog button to gauge the feeding performance of a few pieces of product. If necessary, Jog the feeder while adjusting the Separator until product is feeding evenly. Ideally, you are looking for a 1" gap between the products as it passes the Sheet Sensor photo eye.
5. All products are different in characteristics. While you may be able to load higher stack heights of one product, the next product you run may require lower stack heights for optimal performance. For example, thin or flimsy sheets may only perform at a 3" to 4" stack height while more ridged products such as chipboard and corrugate can be stacked in excess of 24". You will need to experiment by loading or unloading product to determine the effective stack heights for each product. Use the chart below as a general guideline on product stack heights.

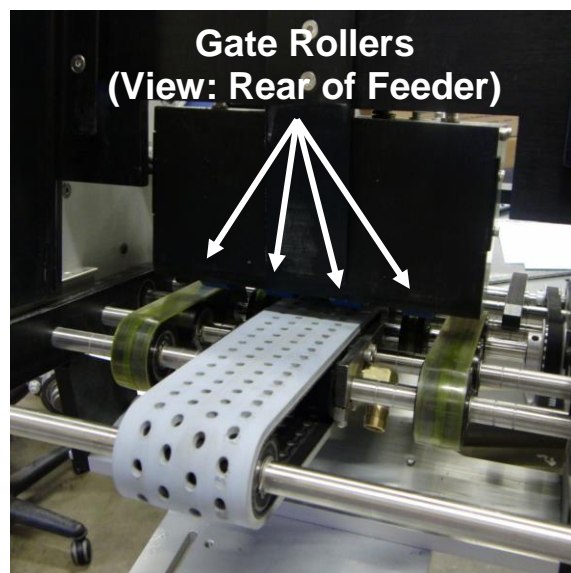

Product Types	Thin, Flimsy Sheets	Glossy Sheets	Card Stock	Corrugate
Stack Height	3 to 6"	4 to 8"	8 to 20"+	10 to 20" +

Xtreme XM Series Friction Feeders can run over 2,000 different products; however, it is impossible to provide a complete setup guide for all products types. You may experience significantly different stack height results than what is listed above. For maximum results, use trial-and-error to find the optimal stack height for your specific product type.

6. Once you have achieved consistent feeding performance, set the batch size to the desired number of pieces to be dispensed each cycle. This is done by rotating the thumb wheels next to the “Batch Size.” “01” represents that one piece will dispense per cycle, also known as One-Shot feeding. Note: If batch size is set to “00” the feeder will continually feed until the stop button is pressed.
7. As you start feeding, you can add or remove product to adjust your stack height. Be sure to keep a consistent stack height as the feeder runs because the weight of the stack will affect the performance. For more information on different variables of feeding product, see Additional Setup Information section.

Front Control Panel Features

Jog Button

The feeder will advanced when the Jog button is pressed. The feeder will continuously run when the jog button is activated. This option is typically used when setting up product in the feeder or clearing any product under the Separator. While holding down the Jog button, you can adjust the Separator and feed product until the product feeds consistently.



Reset Button

The feeder is in Setup Mode when the Reset light is on. The feeder will only respond to the “Jog” input. Pressing the Reset button when lit will put the feeder into Ready Mode. Pressing the Jog button will incrementally advance product through the unit. This will allow you to verify the flow of product through the unit and allow you to make adjustments if necessary.

Ready Mode

Pressing the Reset button will clear the illumination of the reset light and put the unit into “Ready” mode. Ready mode is represented by a solid illumination of the ready lamp (Green). The unit is now ready to receive trigger signals

from one of three sources (green cycle button, trigger sensor, or externally through the I/O interface).

Stop Mode

If a miss-feed or jam occurs, press the “Stop” button to put the feeder in Stop Mode. Stop Mode is represented by a solid red lamp on the stop button and a solid amber lamp on the reset switch. The feeder will not be able to receive a signal and you can safely clear any jammed product or make any necessary adjustments. When you are ready return to Ready Mode, press the Reset button.

Batch Size Thumb Wheels

The Batch Size thumb wheels can be set to your desired batch size. The XM-1 has two thumbs wheels to create batches up to 99 pieces. For one-shot (a.k.a. on demand) feeding, set the Batch Size to “01”.

Main Speed Dial

Use the Main Speed dial to set the feeding speed for the application you are running. Turn the Main Speed dial to the setting that suits the product best. This setting will vary from product to product so you will need to experiment based on line speed and control of the product as it is dispensed. *Note:* Never set the Main Speed Dial *lower* than the End-of-Batch Speed Change dial. This will speed up the last piece in a batch count as it exits the feeder discharge.

- Xtreme XM-1 maximum belt speed: 210 ft. /min
- Xtreme XM-12HS maximum belt speed: 370 ft. /min
- Xtreme XM-12 Ultra maximum belt speed: 750 ft./min

Trigger Delay Dial

This option is designed to create a gap, or lag time, between when the feeder receives a signal from the Trigger Sensor and when the feeder begins to cycle. For most applications, the Trigger Delay dial can be set to the “-” sign. For applications such as feeding into a flighted conveyor when the Trigger Sensor is set to detect a passing lug, this option is designed to help aim where in the conveyor pocket the product is dispensed. To experiment with this option, set the Trigger Delay dial to “-” and move your finger in front of the Trigger Sensor noting the feeder delay. Then set the Trigger Delay dial to the “+” and repeat the motion. There will be a significant delayed between when the feeder receives the signal and when the cycle begins. See the Trigger Timing Reference for a setup illustration.

End-of-Batch Speed Change

The End-of Batch Speed Change consists of two settings: a dial and a thumb wheel. This option is designed to slow down the last piece is a batch count. When the thumb dial is set to “0”, this option will be disengaged. By setting the thumb wheel to “1”, this will slow down the last piece in the batch. Rarely will this need to be set greater than “1”. This option is ideal when running smaller products and at high speeds because it will slow down the last piece in the count without shooting past the Sheet Sensor photo-eye.

To experiment with this option, load some product into the feeder and set a Batch Size to “05”. Set the Main Speed to 2/3 or 2 o’clock, and set the End-of-Batch Speed Change thumb wheel to “1” and the dial to 1/3 or 10 o’clock. Manually cycle the feeder. You will notice the last piece slow down as it exits the feeder.

Now, set the Main Speed to 1/3 or 10 o’clock, and set the End-of-Batch Speed Change to 2/3 or 2 o’clock and manually cycle the feeder. You will notice the last piece in the batch speed *up* as it exits the feeder.

Note: Never set the End-of-Batch Speed Change thumb wheel equal to or greater than the Batch Size. This will create inaccurate counts.

Shutdown

Completely power off the feeder when not in use. To do this, move the on/off switch located on the Rear Control Panel to the “off” position (O) and remove the product from the hopper.

Rear Control Panel Features



Time-Out

When enabled, the Time-Out function detects changing states during a cycle. If the sheet sensor photo eye is covered or uncovered for 2 seconds or greater during a cycle, the feeder will go into Stop Mode. To continue:

1. Clear any jams in the feeders
2. Load product in the feeder, if empty
3. Relocate the sheet sensor so it is not positioned over a shaft or other obstructions.

Miss Detect

When Miss-Detect is enabled, feeder will go into to Stop Mode if a Trigger Signal is received before a cycle is complete. To resolve, either:

1. Slow down the line,
2. Speed up the feed, or
3. Possibly turn down the Trigger Delay

Double Detect

Depending on when you purchased your feeder, Double Detect will come as an aftermarket option or as a standard option. When enable, the feeder will go into Stop Mode when double product is detected. To resolve:

1. Be sure the Double Detect is properly setup. See Section 2: Setup, Electro-Mechanical Double Sheet Detect Setup instructions.
2. Be sure there is a gap between products as it passes the Double Detect.

External Interface – See I/O wiring detail.

Power Inlet – Switchable to 110 / 220 vac.

Vacuum Belt and Manifold

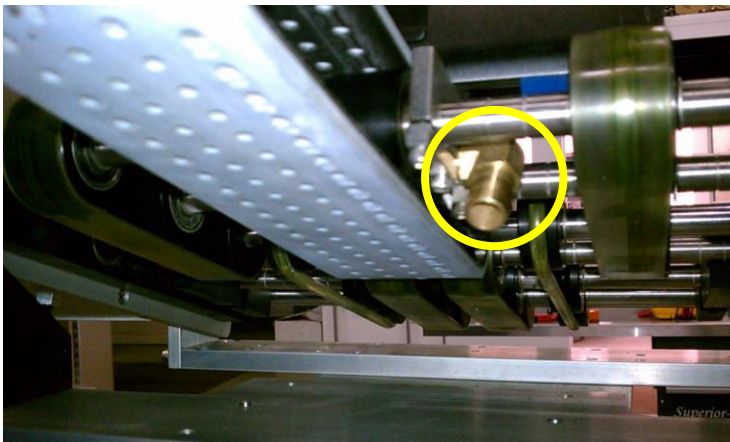

The vacuum manifold has a 1/2" barbed fitting. Any 1/2" hose can be attached. Works with any vacuum source provided by customer: Venturi - House Air, Pump, or Regen Blower. We recommend an adjustment valve be placed between the vacuum source and the vacuum manifold. The amount of vacuum required depends on product type and application speed. Range 1.0 to 20 in-Hg.

Trigger Delay Timing Reference

The Xtreme XM batch count feeders come standard with a feature called “Trigger Delay”. The setting for this feature is located on the front controls panel. This feature allows the operator to offset products within the pocket of a lugged conveyor when using the trigger sensor or external trigger interface. Below is an example to demonstrate how the Trigger Delay feature works.

Trigger Delay Setting – Line speed 60 per/min

Figure 1 Full Minimum
- Feeds the front of the pocket almost immediately

Figure 2 1/2 Setting (feeds half way into the pocket)
- Conveyor will travel ½ of the pocket length before the feeder dispenses the product

Figure 3 3/4 Setting (feeds the rear of the pocket)
- Conveyor will travel ¾ of the pocket length before the feeder dispenses the product

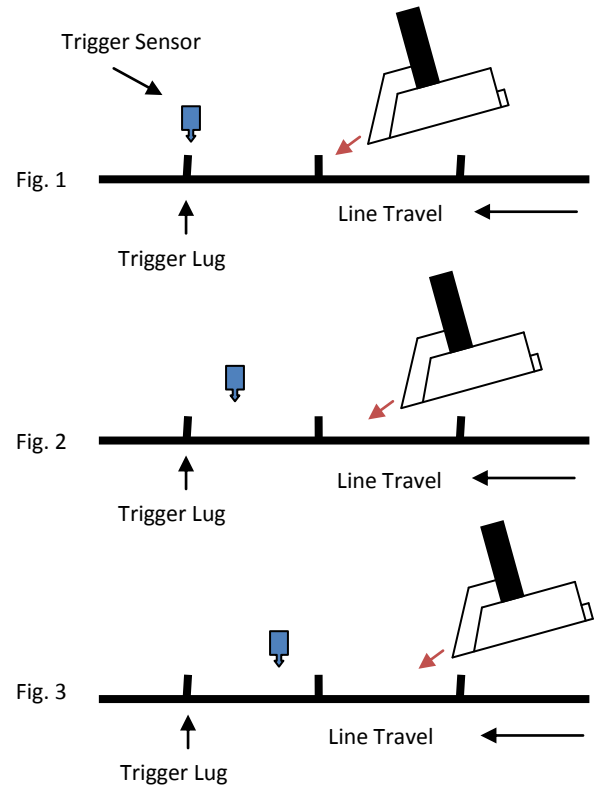

Below you will see a timing chart of how the position of the trigger delay dial will affect each feed cycle.

Figure 1 shows full minimum delay, thus an immediate feed cycle once triggered.

Figure 2 represents feeding the middle of the pocket – at a line speed of 60 ppm, this dial position would be at ½.

Figure 3 represents offset to the rear of the pocket.

TRIGGER DELAY TIMES (dial position)

- Full Minimum = 8ms 1/4 = 250ms
- 1/2 = 500ms 3/4 = 750ms
- Full Maximum = 1020ms (just over 1 second)

TIMING CHART

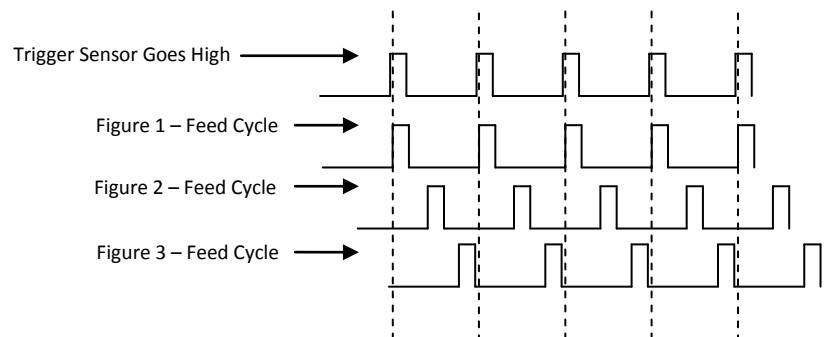

Additional Set-Up Information

Different Variables of Feeding Product

In any friction feeder there is an inherent trade-off between stack height (load weight) and feeding performance. Smaller products like most 5" x 7" and smaller can stack 16" to 20". Larger products vary greatly in their stack height. Variables include:

- Coefficient of friction of the product such as glossy sheets versus card stock;
- Rigidity of the product such as paper versus chipboard;
- Weight of the product such as a 3" stack of paper versus a 3" stack of corrugate pizza backers.

Products of the exact same size can vary greatly in the maximum stack height allowed at full speed. It is not uncommon to have stack heights in the 4" or less range for higher coefficient of friction 8.5 x 11 (or larger) thin sheets.

If full speed is the primary goal, then stack heights may need to be reduced. If maximum stack heights are the goal, then speeds may need to be reduced. If the goal is to run at full speed with maximum stacking capacity, a bulk loader is the only available solution for some products. Please see the XM-100 Bulk Loader in the Section 6: Accessories and Aftermarket Options.

Repositioning the Separating Rollers

The purpose of repositioning the separating rollers off the belt is to create a "flex" separation (figure 1) vs. nip point separation (figure 2). This can be done with the separator mounted or removed from the feeder. The preferred method is to remove the separator.

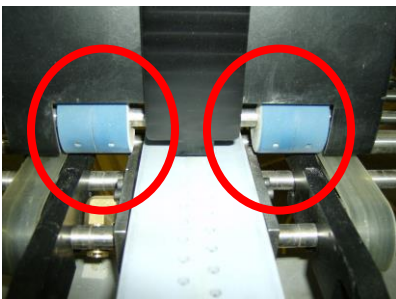

Figure 1

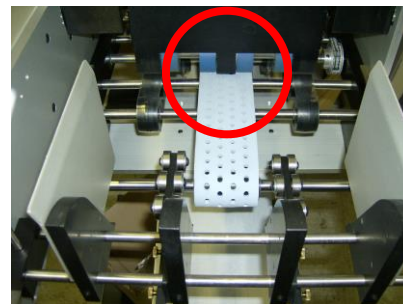

Figure 2

The blue gate rollers are designed to move anywhere on the 8" wide gate roller shaft. Most customers leave the 2 rollers over the feed belt as it is easier for most operators to set-up a wide range of product with these rollers in this position. There is no reason all 4 blue rollers could not be over the feed belt, or all 4 off the feed belt. If all 4 are off the feed belt, then you cannot feed product that is narrower than the distance between the inner two blue rollers – two blue rollers need to be in contact with the product if the rollers are off the belt.

We space the rollers apart at the factory so 2 are on the belt for feeding smaller products and 2 are wider for larger products to help with reducing skew. If all 4 rollers are over the belt, for wider products there might be more skew. If all 4 rollers are off the belt, then the gate rollers can be lowered past the top surface of the feed belt. This can help in separation of thin sheets because the product must bend down and around the rollers, the forming of a "wave"

in the product creates a natural fanning – starting separation – of the sheets. This can improve the stack heights, or improve feeding speed performance. By having the blue rollers off the feed belt, it also eliminates the hard nip point created between the gate rollers and the feed belt, without this nip, stress is relieved from the leading edge of the sheet, and leading edge marking can be reduced or eliminated. It is never recommended to try and lower the gate rollers below the surface of the feed belt for thicker products. Lowering the gate roller too far below the surface of the feed belt can cause marking or scoring of the product due to too much pressure of the product on the edge of the belt and gate rollers.

Rotating Gate

****BE SURE TO POWER OFF THE FEEDER BEFORE REMOVING POWER TO THE SEPARATOR**

Xtreme feeder's ship with the gate rotation set to "Reverse". In fact, you can remove the gate power cable so that it is not plugged in and the rollers are not turning at all, and the feeder will still function properly. The primary function of the rotating gate rollers are to create uniform wear and not create flat spots on the rollers that would require the operator to stop the feeder and correct. The rotation rate is approximately 4.25 to 4.5 minutes per revolution. The blue gate rollers only rotate when the feed belt is moving. You will not see the rollers rotate if only looking at them for 10 to 15 seconds.

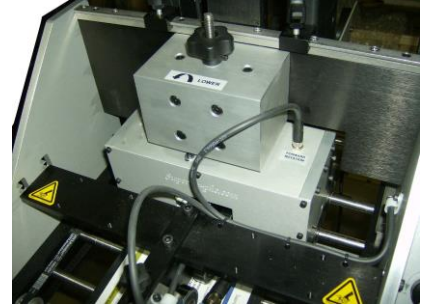

The best way to verify the blue rollers are turning is to remove all product from the feeder, set the feeder count to "00", set Time Out switch on back of feeder to off, set speed to about 50%, place a finger on one of the rollers, then press the Cycle button on the front of the feeder. With the feeder set to "00" count the feeder will run continuously without stopping. You will feel the gate rollers pulse and rotate. If you would prefer not to set a finger on the roller, you can mark a line on a roller, or locate a set screw hole and observe these as the rollers turn.

SECTION 4: WIRING AND ELECTRICAL DETAIL

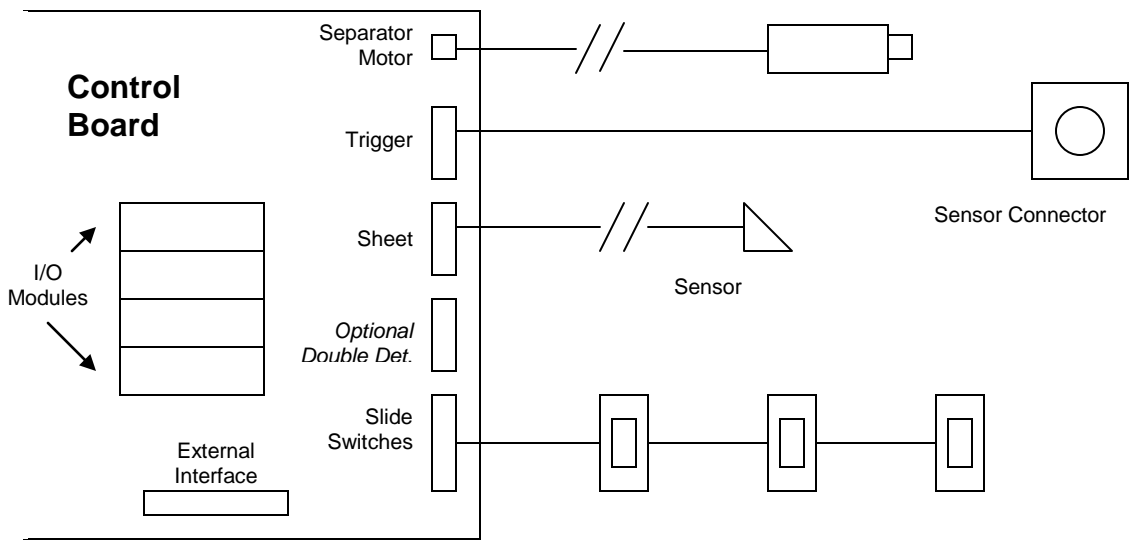
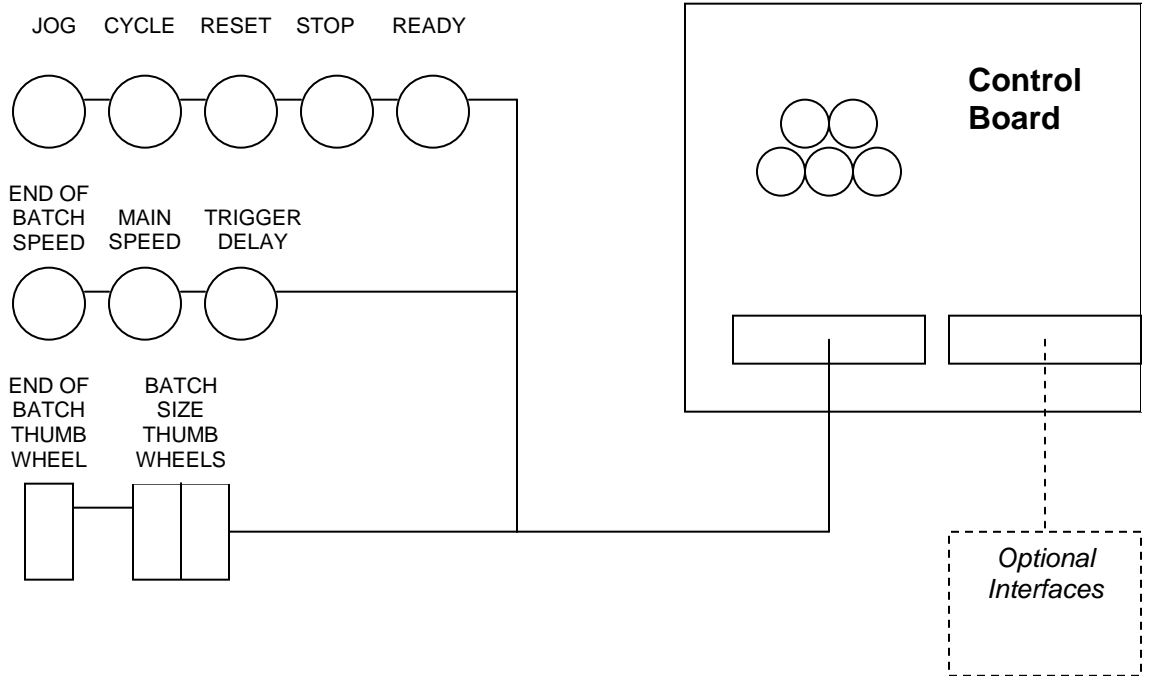

WIRING AND ELECTRICAL DETAIL continued

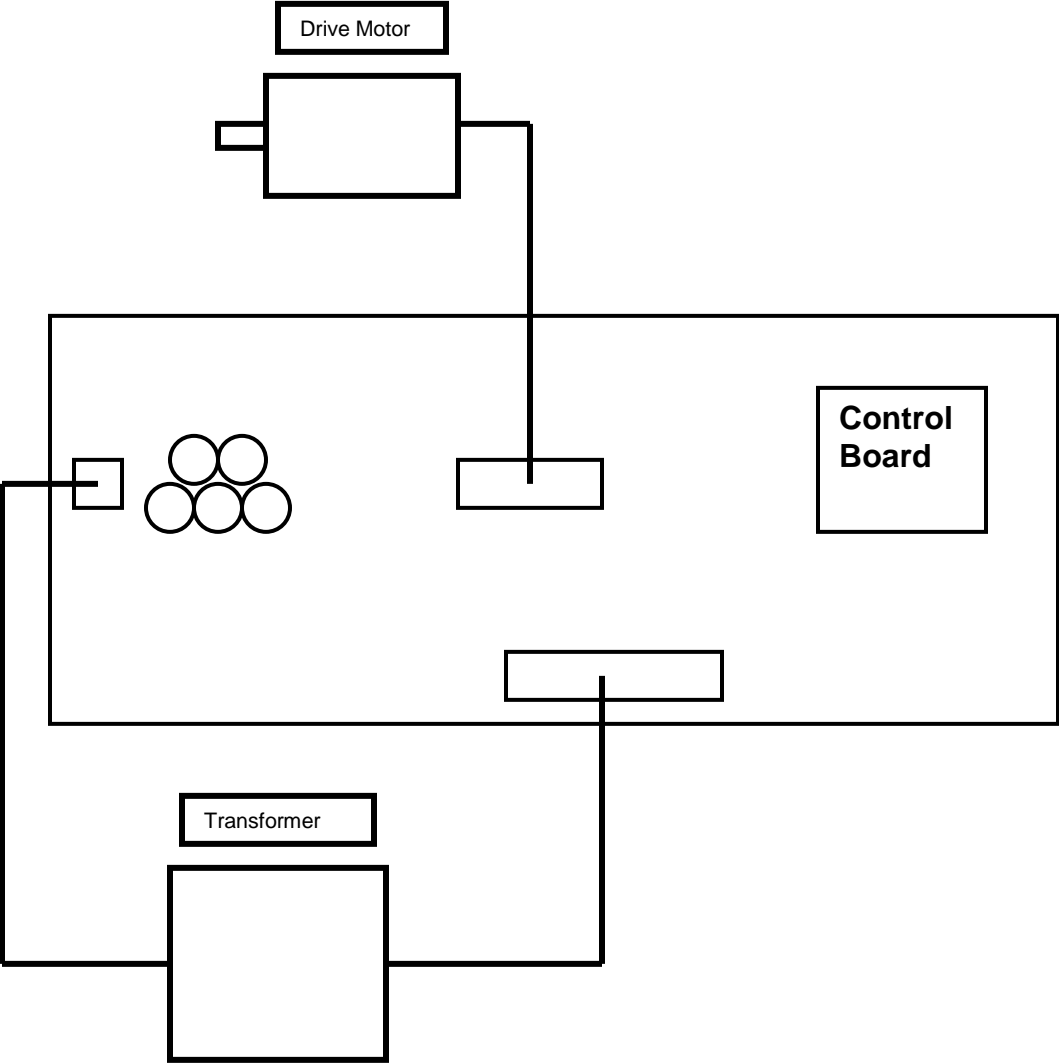

WIRING AND ELECTRICAL DETAIL continued

I/O Signal Reference Guide -

I/O Wiring Detail – XM Series Feeders

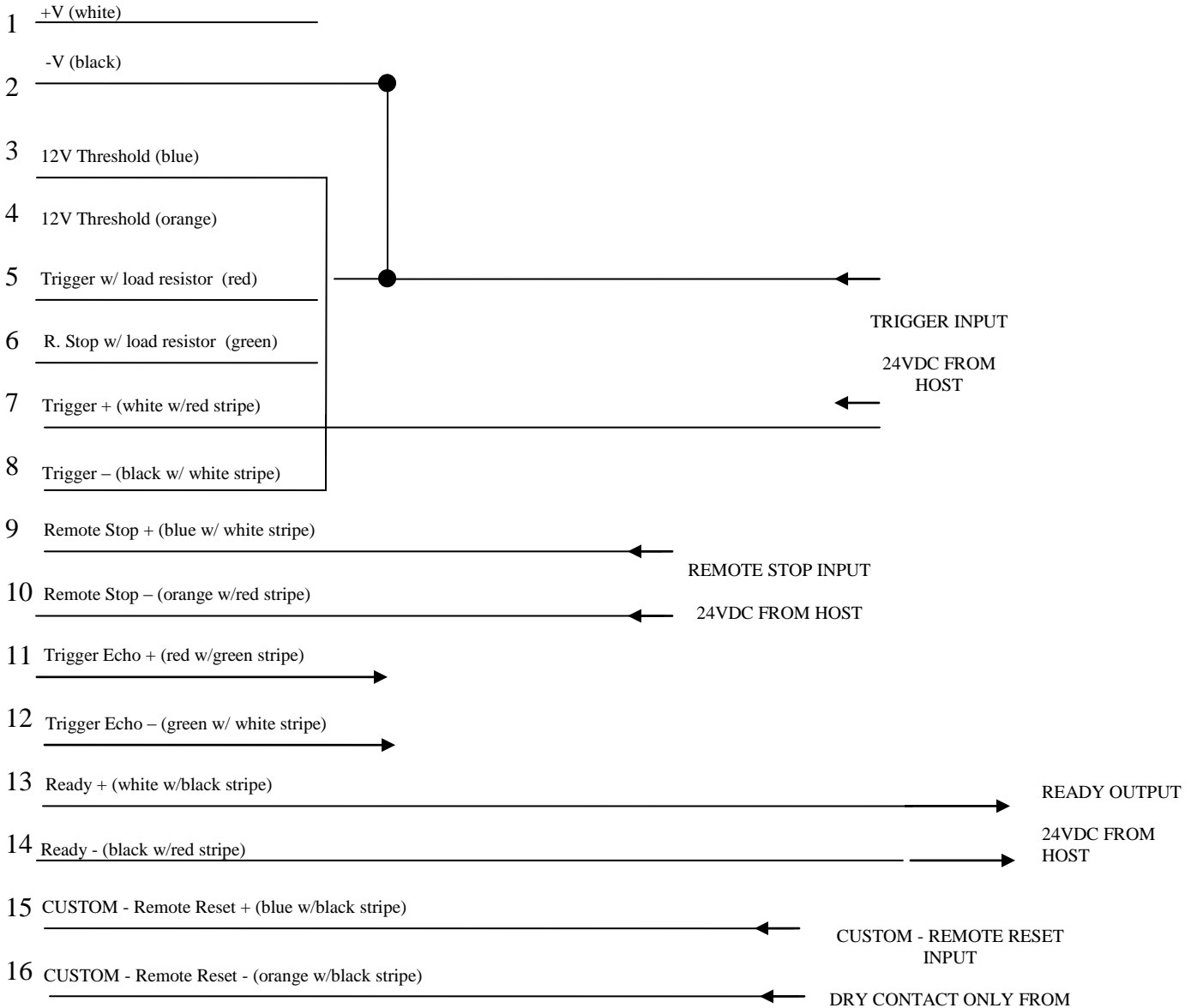

**WARNING! - DRY CONTACT ONLY
DO NOT APPLY POWER TO WIRES 15 & 16
THIS SIGNAL DOES NOT GO THROUGH A RELAY**



External Interface I/O Detail (s/n 10010130+)

(SSR = Solid State Relay)

External Cable Assembly Sold Separately

Pin #	Wire Color	Function
1	White	+24VDC Power
2	Black	0VDC Ground
3	Blue	+12VDC Threshold
4	Orange	+12VDC Threshold
5	Red	PNP Trigger Input + w/ load resistor
6	Green	NPN Trigger Input + w/ load resistor
7	White w/ red stripe	SSR Trigger Input +
8	Black w/ white stripe	SSR Trigger Input -
9	Blue w/ white stripe	SSR Remote Stop Input +
10	Orange w/ red stripe	SSR Remote Stop Input -
11	Red w/ green stripe	SSR Trigger Echo Output +
12	Green w/ white stripe	SSR Trigger Echo Output -
13	White w/ black stripe	SSR Ready Output +
14	Black w/ red stripe	SSR Ready Output -
15	Blue w/ black stripe	Used for Options Like Remote Reset
16	Orange w/ black stripe	Used for Options Like Remote Reset

To avoid sharing power between the feeder and host system, the following is the recommended wiring solution for communication between each piece of equipment. The XM-1 Feeder will supply operating voltage for the following signals;

External Trigger Input PNP

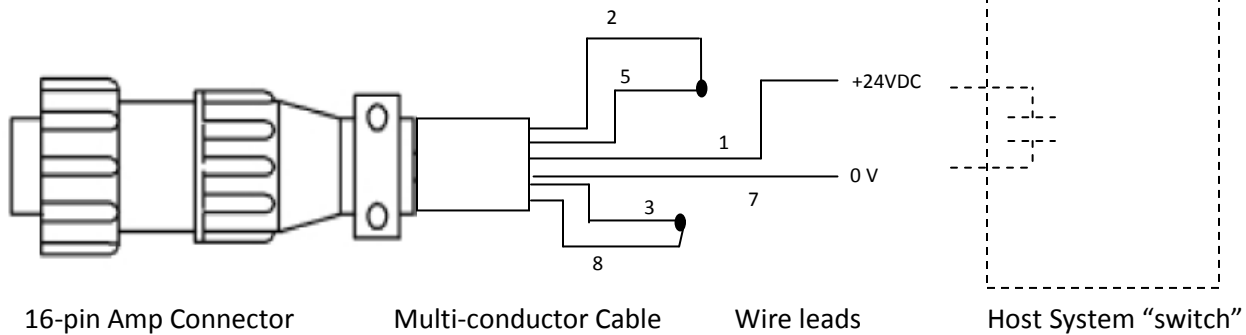

16-pin Amp Connector

Multi-conductor Cable

Wire leads

Host System "switch"

External Trigger Input NPN

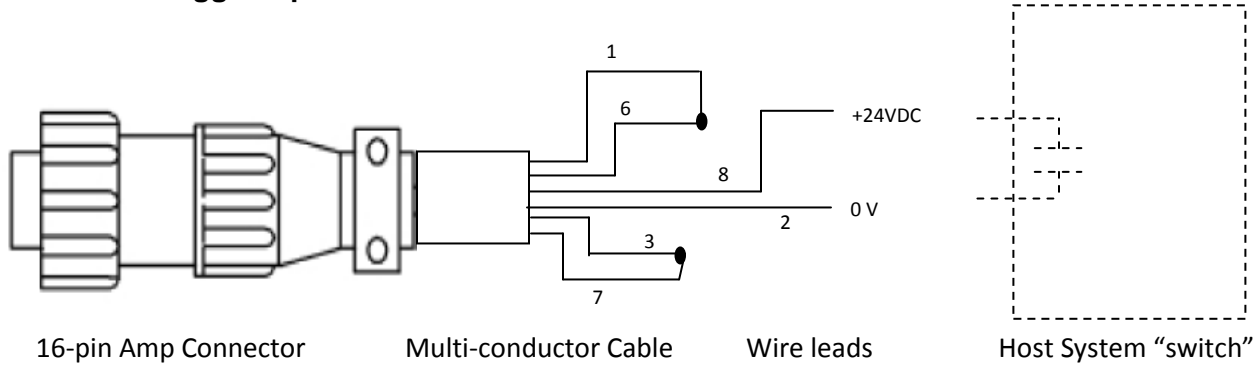

Remote Stop Input PNP

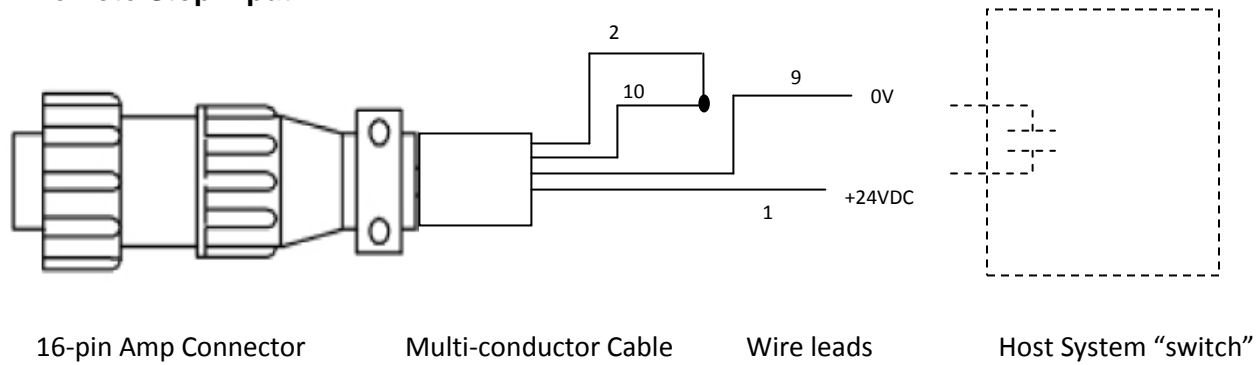

Remote Stop Input NPN

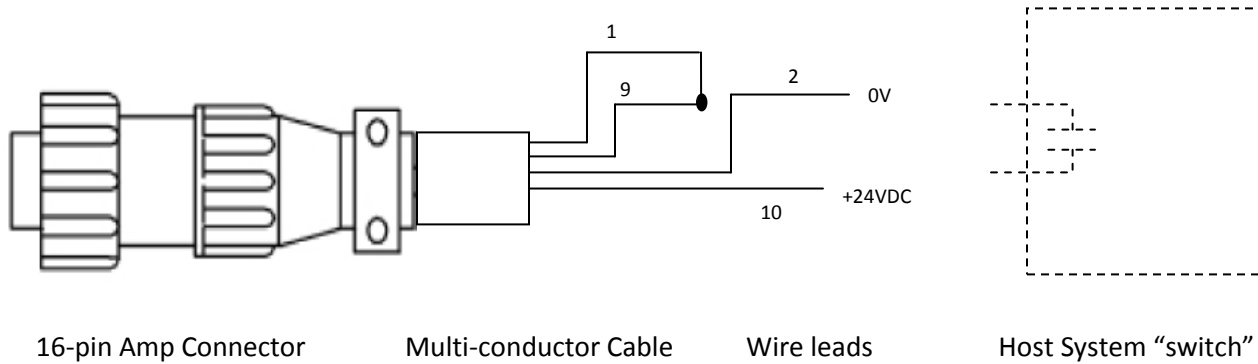

Ready Output PNP

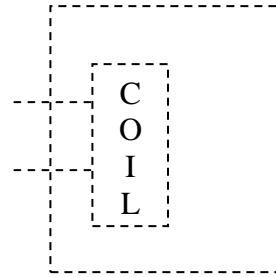
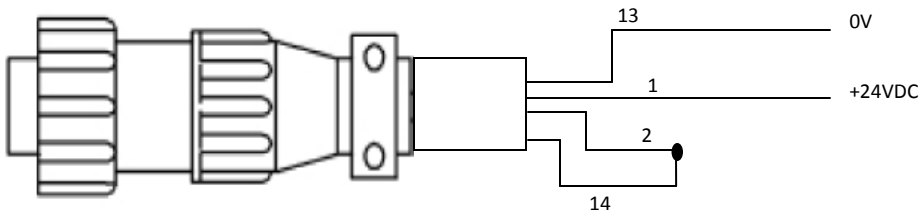

16-pin Amp Connector

Multi-conductor Cable

Wire leads

Host System "coil"

Ready Output NPN

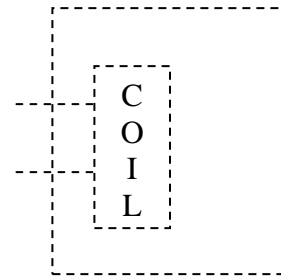
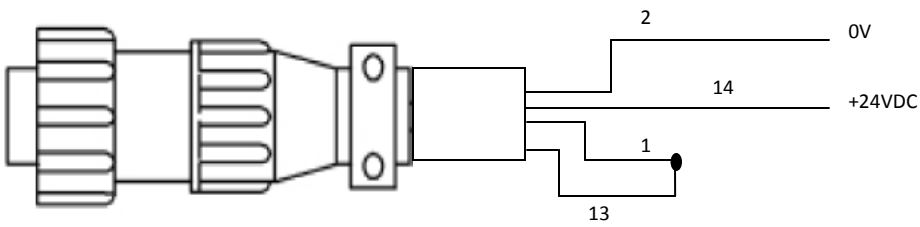

16-pin Amp Connector

Multi-conductor Cable

Wire leads

Host System "coil"

Trigger Echo Output

This is a custom cable that is prefabricated at the factory and cannot be field wired

SECTION 5: COMPONENTS / PARTS LIST

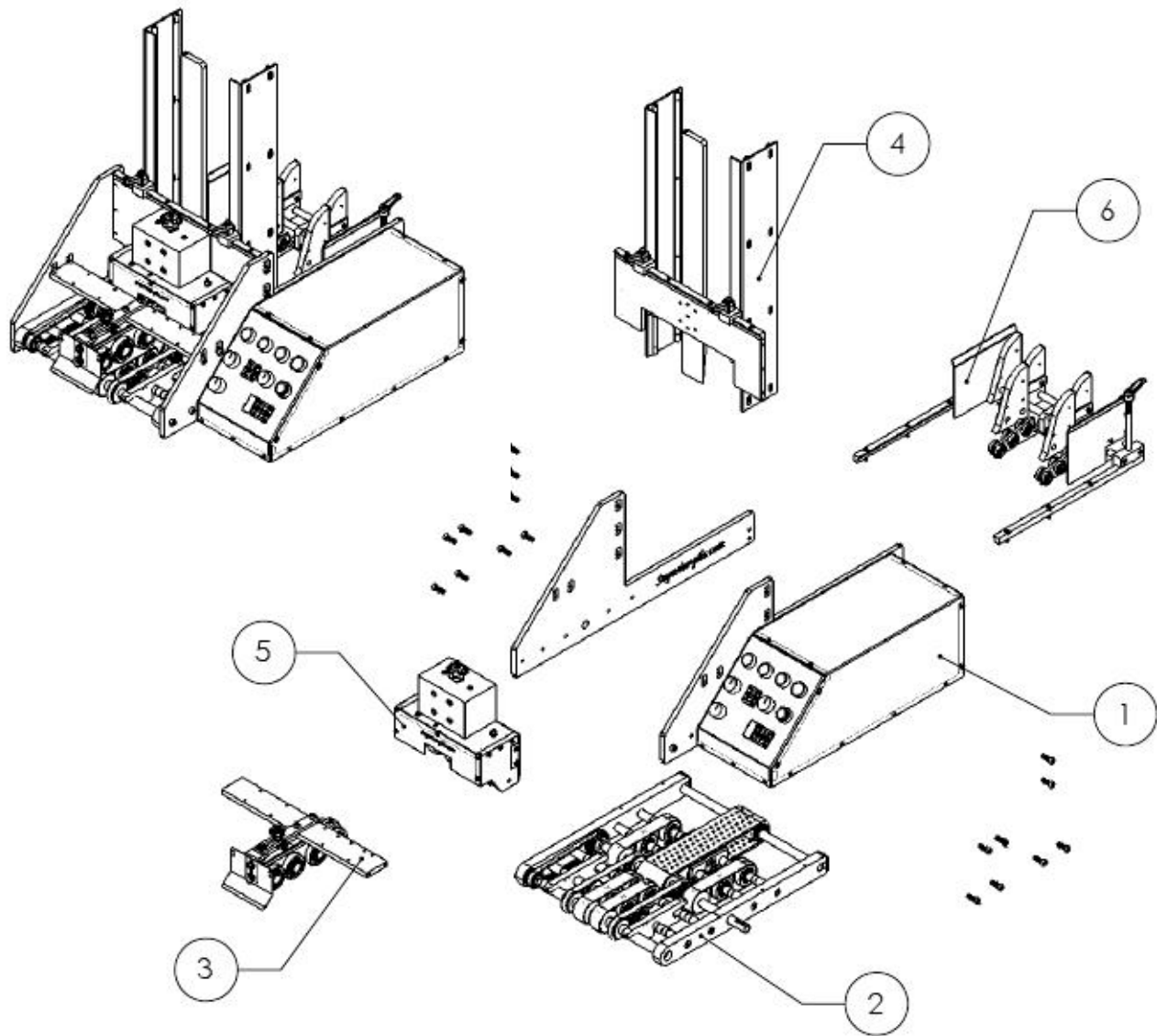

Item	Description
1	Carriage Assembly
2	Control Cabinet
3	Hopper Assembly
4	Separator Assembly
5	Hold Down Assembly
6	Wedge Assembly

Carriage Assembly

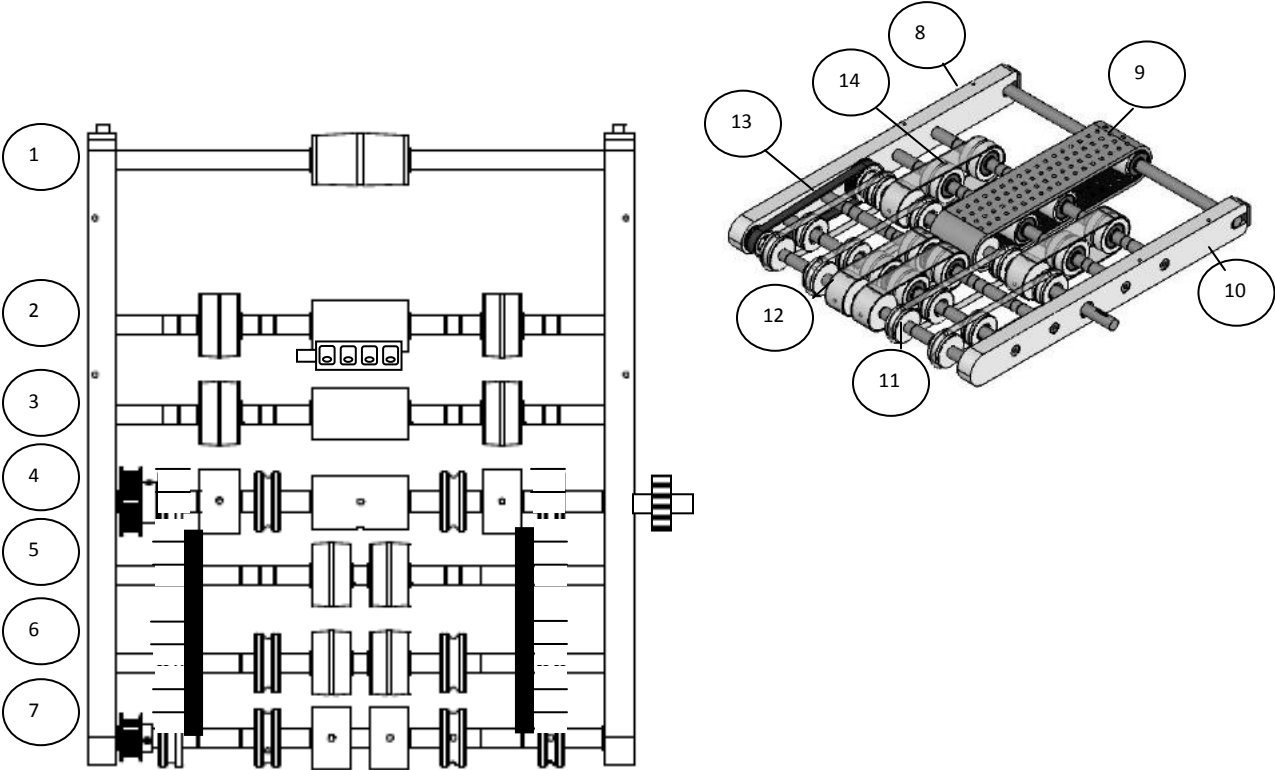

Carriage Assembly

Item	Description	XM-1
1	Rear Idler Shaft	100142
	Crowned Idler Pulley Long	100149
	Timing Idler Pulley	
	R8 Bearing	100141
	Tension plate	100161
2 / 3	Idler Shaft (Feed Section)	100139
	Crowned Idler Pulley Short	100148
	Flat Idler Pulley Long	100150
	R8 Bearing	100141
	Vacuum Manifold Block	100607
	90-degree Barbed Fitting	100613
4	Main Drive Shaft (Thomson Hardened SST)	100231
	Aluminum Timing Pulley 24XL037, .500 bore (speed up)	100195
	Aluminum Timing Pulley 22-5M-15	
	Idler Pulley O-Ring	100144
	R8 Bearing	100141
	Flat Drive Pulley Short (.500 bore)	100152
	Flat Drive Pulley Short (.750 bore)	
	Flat Drive Pulley Long	100151
	Timing Drive Pulley	
Aluminum Timing Pulley 20XL037, .500 bore, keyed (Drive)	100245A	
5	Discharge Shaft, Rear	100139
	Crowned Idler Pulley short	100148
	R8 bearing	100141
6	Discharge Shaft, Center	100139
	Crowned Idler Pulley short	100148
	R8 Bearing	100141
	Idler Pulley O-Ring	100144
	Support Rail, Snap In	100439A
7	Discharge Drive Shaft (.625)	100138
	Discharge Drive Shaft (.750)	
	Aluminum timing pulley 15XL037, .500 bore, keyed	100543
	Aluminum timing pulley 15-5M-15	
	R8 Bearing	100141
	Drive Pulley, O-ring (.625 bore)	100191A
Flat Drive Pulley Short (.625 bore)	100152A	
8	Right Carriage Holder	100137B
	R8 bearing	100141
9	Feed Belt	100157
10	Left Carriage Holder	100136B
	R8 Bearing	100141
11	O-Ring	100156
12	Discharge Belt	100159
13	Timing Belt 160XL037	100196
	Timing Belt 400-5M-15	
14	Idler Belt	100158

XM-20v Carriage

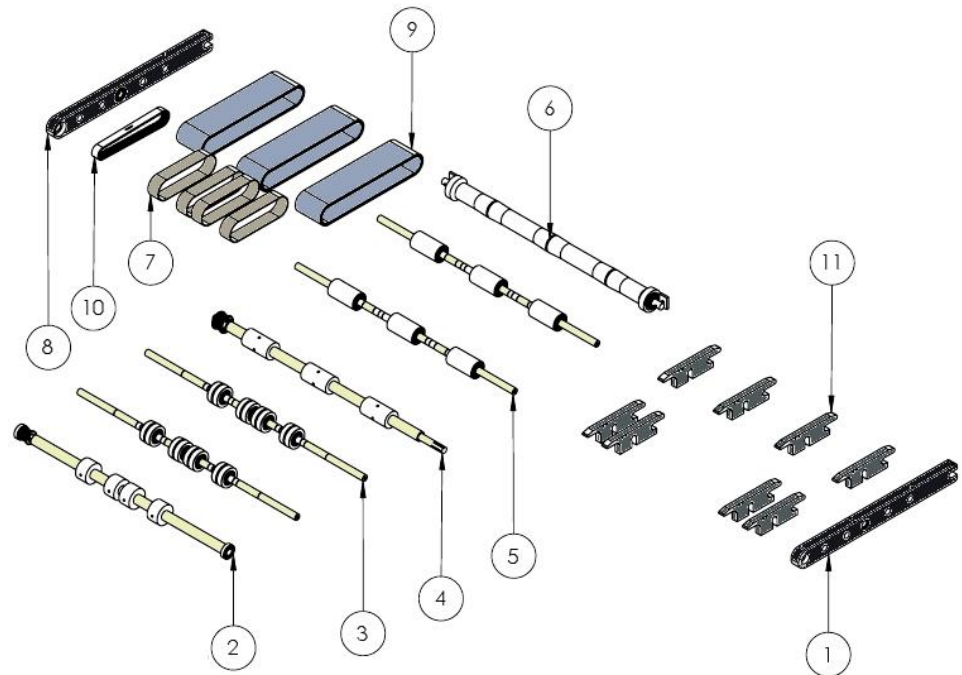

Item	Description	XM-20U	Qty.
1	Carriage LH Assembly	400066	1
	Left Carriage Holder	300453	1
	R8 Bearing	100141	2
2	Drive Shaft Assembly XM-20	400076	1
	Drive Shaft	300212	1
	Flat Belt Drive Pulley Assembly .750 bore	400075	4
	R8 Bearing	100141	2
	Stainless Steel External Snap Ring ½"	390047	1
	15T Timing Pulley Assembly	400113	1
3	Idler Shaft Assembly Discharge XM-20	400077	2
	Idler Shaft	300216	1
	Pulley Idler Crown Short Assembly	100148	4
	Stainless Steel External Snap Ring ½"	390047	8
4	Main Drive Shaft Assembly XM-20	400080	1
	Main Drive Shaft	300210	1
	Drive Pulley Assembly .750 Bore	400079	3
	Stainless Steel External Snap Ring ½"	390047	1
	20T Timing Pulley Assembly	400114	1
	1/8" Key SST	300650	1
5	Idler Shaft Assembly Rear	400078	2
	Idler Shaft	300216	1
	Flat Idler Long Assembly	100147	3
	Stainless Steel External Snap Ring ½"	390047	6
6	Rear Crowned Idler Pulley Assembly	400081	1
	Rear Idler Shaft One Piece	300221	1
	R10 Deep Groove Ball Bearing	300222	2
	Rear Idler Shaft	300211	1
	Stainless Steel External Snap Ring 5/8"	300856	2
7	Carriage, Discharge Urethane Belt	100159	4
8	Carriage RH Assembly	400053	1
	Right Carriage Holder	300454	1
	R8 Bearing	100141	2
9	Carriage, Feed Belt 2.5"W	300224	3
10	400-5UM Timing Belt	N/A	1
11	Product Support Wedge	300223	8

Chassis Components

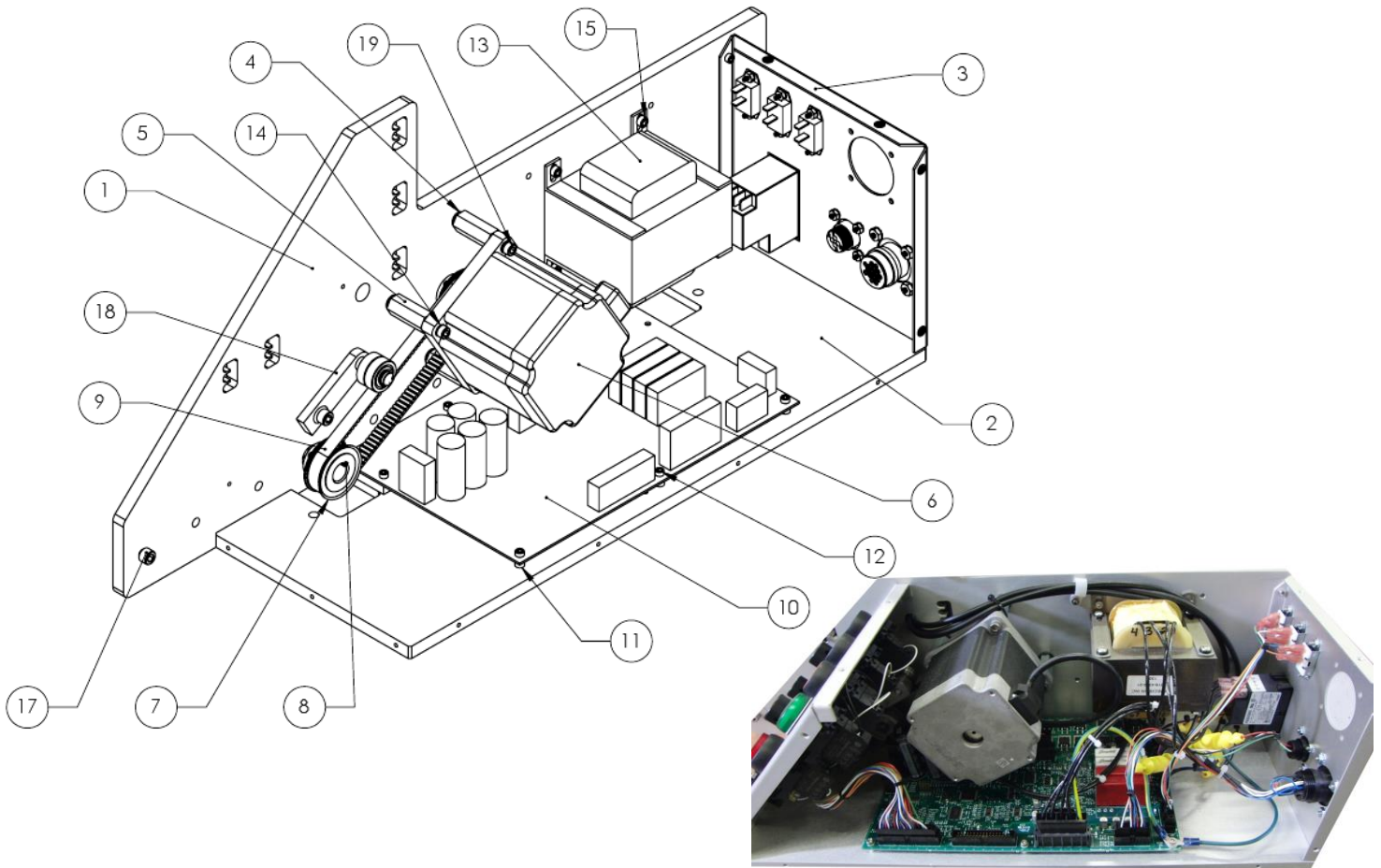

Item	Qty.	Description	XM-1	XM-20v
1	1	Side Plate Left Chassis	100224	100224
2	1	Main Chassis Plate	100226	100226
3	1	Assembly, Rear Panel Controls	100228A	100228A
4	4	Rubber Grommet	100276	100276
5	4	Hex Head Stand Off 10-32 Motor Mount	100237	100237
6	1	Assembly, XM-1 Stepper Motor w/ Connector	100406	
	1	XM-12 Motor Assembly with Connector and pulley		100406A
7	1	20T Timing Pulley	100245A	100245A
8	1	1/8" Key SST	300650	300650
9	1	150XL037 Timing Belt	100247	100247
10	1	Circuit Board with XM-1 Code Downloaded	100239-XM1	
	1	Circuit Board with XM-12 Code Downloaded		100239-XM21
11	3	1/4" x 1/4" Aluminum Spacer	100376	100376
12	3	Stainless STL Socket Head Cap Screw 6-32 x 3/4"	390016	390016
13	1	Transformer	100238	100238
14	4	Stainless Steel Split Lock Washer #10	390041	390041
15	4	Stainless STL Socket Head Cap Screw 8-32 x .375"	390262	390262
16	5	Stainless STL Socket Head Cap Screw 6-32 x 5/16"	390014	390014
17	1	Stainless STL Socket Head Cap Screw 1/4-20 x 3/8"	400042	400042
18	1	Belt Tensioner Assembly	400047	400047
19	4	Stainless STL Socket Head Cap Screw 10-32 x .750"	390023	390023

Hopper Assembly

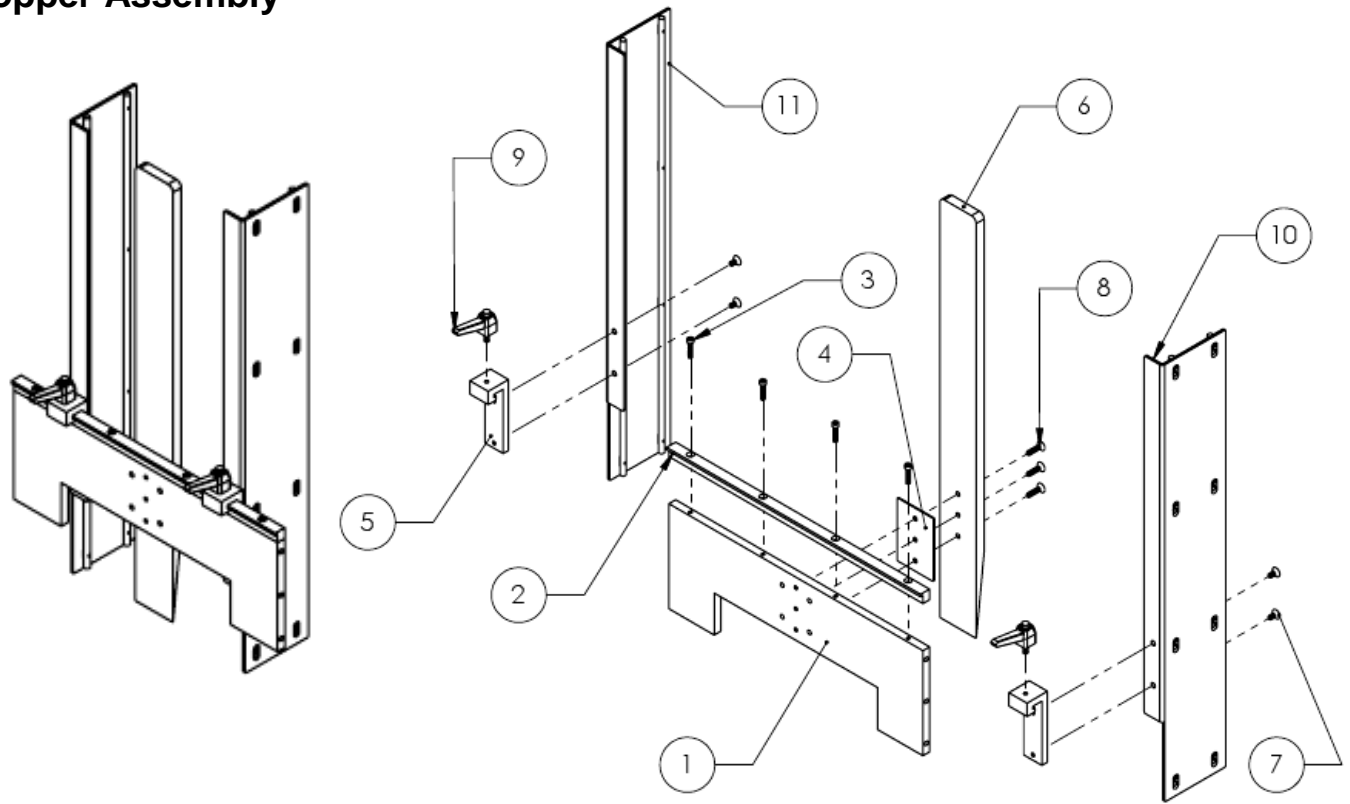

Item	Description	XM-1	XM-20v
1	Hopper Plate Mount	100199	300214
2	Hopper, Guide Rail	100202	300213
3	Stainless STL Socket Head Cap Screw 8-32 x 3/4"	390019	390019
4	Center Hopper Shim Plate	300651	300651
5	Hopper, Guide Clamp	100203	100203
6	Hopper, Center Plate	100201	100201
7	SS Flat Head Socket Cap Screw 10-32 x 3/8"	390020	390020
8	SS Flat Head Socket Cap Screw 10-32 x 3/4"	390021	390021
9	Adjustable Handle 10-32 x 1/2"	100373	100373
10	Side Guide Hopper Left Assembly	100205	100205
11	Side Guide Hopper Right Assembly	100204	100204

Separator Assembly

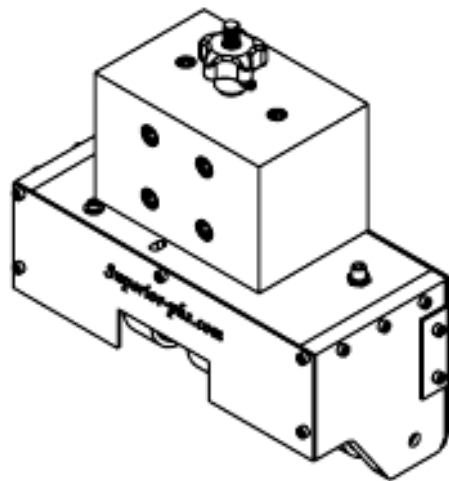
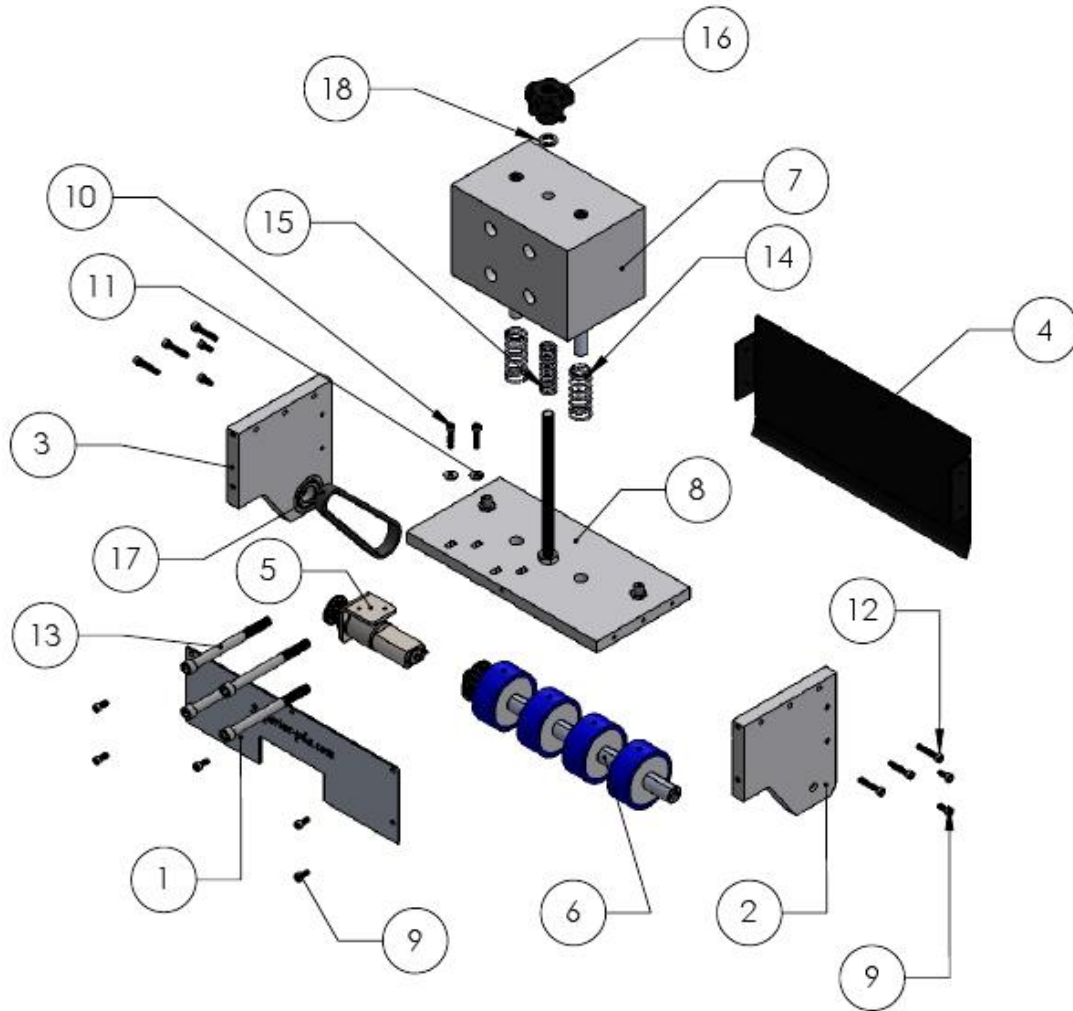

Separator Assembly

Item	Qty.	Description	P/N XM-1	P/N XM-20v
1	1	Front, Powered Separator	100165	100165
2	1	Side Right Powered Separator	100167	100167
3	1	Side Left Powered Separator with bearing	100168	100168
4	1	Lead-In, Pregate Powered Separator	100169	100169
5	1	Separator, Gear Motor 12VDC, 6mm shaft	100163A	100163A
6	4	*Separator, Blue Urethane Separating Roller	100172	100172
7	1	Mount Block Assembly	100170	100170
8	1	Top Plate Assembly	100166	100166
9	9	Stainless SLT Socket Head Cap Screw 6-32 x 5-16"	390014	390014
10	2	Stainless STL Socket Head Cap Screw 6-32 x 5/8"	390015	390015
11	2	Flat Washer #6 Type A	390017	390017
12	6	Stainless STL Socket Head Cap Screw 6-32 x 3/4"	390016	390016
13	4	Stainless STL Socket Head Cap Screw 1/4-20 x 3.00"	390011	390011
14	2	Outside Spring	100372	100372
15	1	Center Spring	100184	100184
16	1	Knob Assembly	100173	100173
17	1	Separator Timing Belt	100187	100187
18	1	Nylon Washer Separator	100378	100378
		Separator Assembly	100164	100164
Not Shown		M8 Bulk Head Connector	100428	100428
Not Shown		M8 quick disconnect cable cut to length, with connector	100429-SEP	100429-SEP
Not Shown		Separator Label Kit	100430	100430

*Roller Options

P/N	Description	Durometer Range
100172	BLUE Urethane Separating Roller	Shore A 65-70
100172A	GRAY Urethane Separating Roller, 83A	Shore A 83
100172B	BLACK Urethane Separating Roller, 92A	Shore A 92
100172C	NATURAL Urethane Separating Roller 50-55A	Shore A 50-55
100172E	Stainless Steel Separator Roller	N/A

Hold Down Assembly (3-piece design)

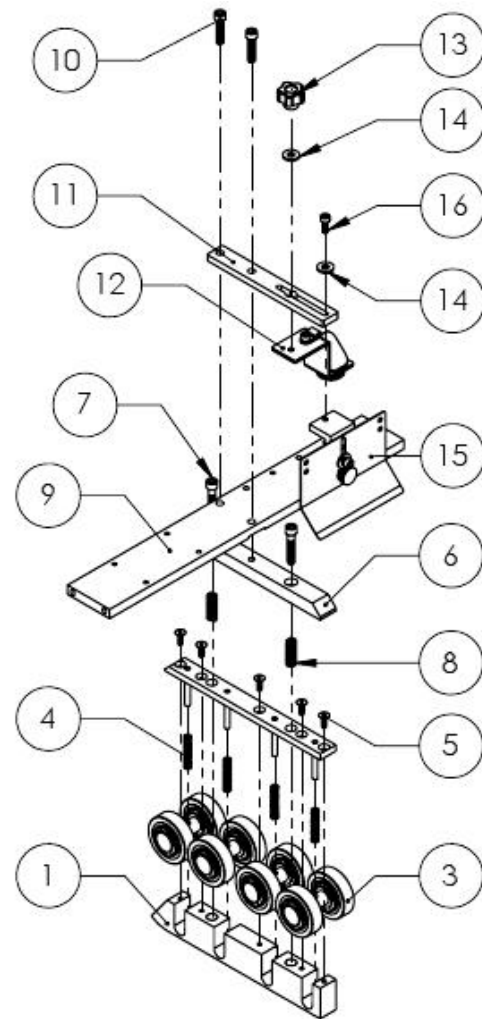
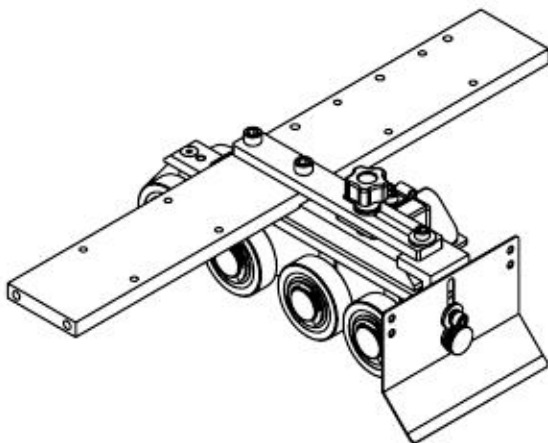

Item	Qty.	Description	XM-1	XM-20v
1	1	3 Piece Hold Dow, Bottom Section	100208C	100208C
2	1	3 Piece Hold Down Mid-Section (400029)	100216C	100216C
3	4	Hold Down Axel Shaft Assembly	100209	100209
4	4	Hold Down Spring .25 dia x 1.25	100212	100212
5	5	Flat Head Socket Cap Screw Stainless STL 8-32 x 1/2"	93791A475	93791A475
6	1	3 Piece Hold Down Top	100208D	100208D
7	2	Self-Locking Stainless STL Socket Head Cap Screw 1/4-20 x 1 1/4"	390029	390029
8	2	Hold Down Micro Adjust Spring	100687	100687
9	1	Hold Down Cross Bar	100213	300215
10	2	Stainless STL Socket Head Cap Screw 1/4-20 x 1.00"	390030	390030
11	1	Mount, Sheet Sensor Bracket	100259	100259
12	1	Sensor Mount Bracket	100260	100260
13	1	10-32 x 1/2" Threaded Knob	100391	100391
14	2	Flat Washer Type A #10	390028	390028
15	1	Deflector Plate, Wide	100566A	400032
16	1	Stainless STL Socket Head Cap Screw 10-32 x 1/2"	390033	390033
N/A	1	NPN Sheet Sensor	100387	100387

Wedge Assembly

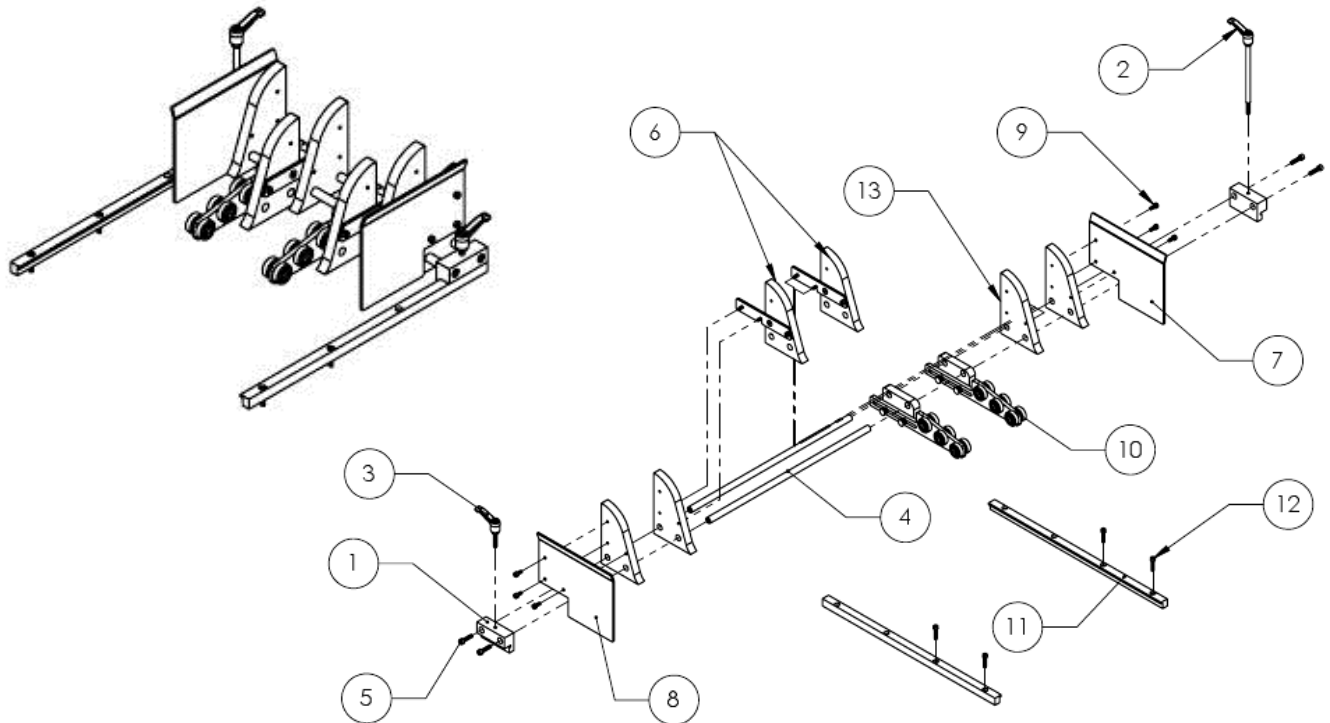

Item	Qty.	Description	XM-1	XM-20v
1	2	Slide Block	100221	300653
2	1	Wedge Handle Extension	100697	100697
3	1	Adjustable Handle 10/32 x 1	100523	100523
4	2	Wedge, Shaft	100220	100220A
5	4	Stainless STL Socket Head Cap Screw 10-32 x .750"	390023	390023
6	1	Small Product Wedge Extension Assembly	100449	100449
7	1	Wedge, Guide Plate Left	100232	100232
8	1	Wedge, Guide Plate Right	100235	100235
9	6	Stainless STL Socket Head Cap Screw 8-32 x .375"	390262	390262
10	1	Roller Support Wedge Assembly	100894	100894
11	2	Hopper, Guide Rail	100202	100202
12	4	Stainless STL Socket Head Cap Screw 8-32 x 3/4"	390019	390019
13	4	Rear Block Wedge Lift Assembly	100222	100222

Sheet Sensor Assembly

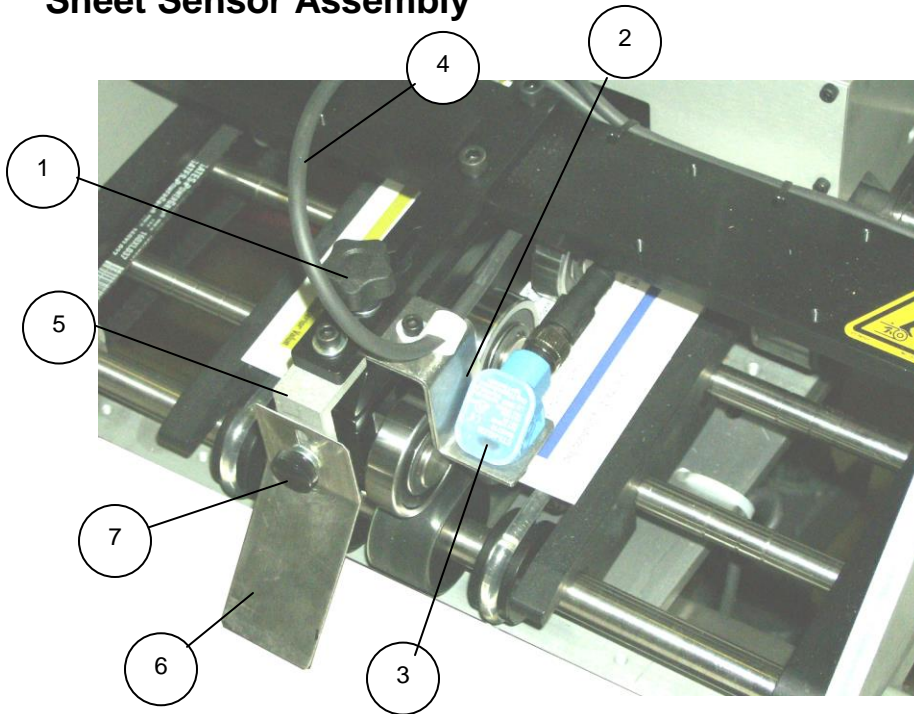

Item	Description	XM-1	XM-20v
1	Knob 10/32 x 1/2 (Sheet Sensor)	100391	100391
2	Sheet Sensor Mount Bracket	100260	100260
3	NPN Sheet Sensor	100387	100387
4	M12 Quick Disconnect Cable (cut to length with connector)	100389-SHEET	100389-SHEET
5	Deflector Mount	100565	100565
6	Deflector Plate, Wide	100566A	400032
7	Knob 10/32 x 3/8 (deflector)	100619	100619

Item	Description	XM-1 / XM-20
1	Sheet Sensor Mount Bracket	100260
2	NPN Sensor ET3-N3228	100387
3	Sensor Lock Nut	N/A
4	.250" P-Clip	N/A
5	Stainless STL Socket Head Cap Screw 10-32 x 3/8"	390031

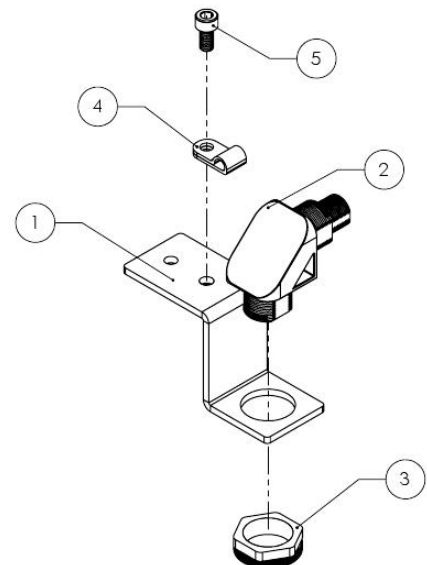

Trigger Sensor Assembly

Assembly Number 100390

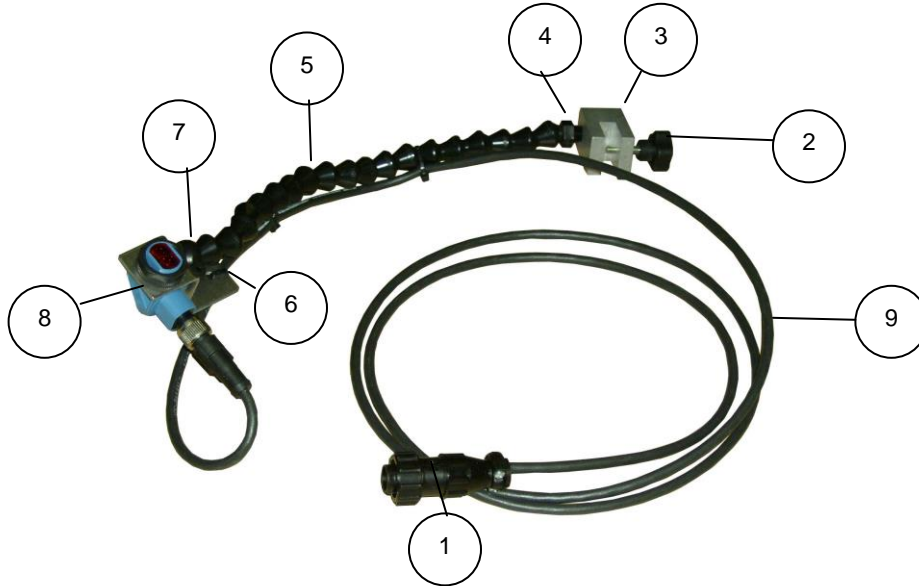

Item	Description	XM-1	XM-20v
1	Circular Plug, Amp 4-pin	100398 100399	100398 100399
2	Lobed Knob 10/32 x 3/4	100392	100392
3	Clamp Mount Block	100261	100261
4	Loc-Line Threaded 1/8 NPT Connector Stud	100394	100394
5	Loc-Line Knuckle set, 10 pcs (20 pieces required)	100393	100393
6	Sensor Mount Bracket	100260	100260
7	Loc-Line Clamp	100395	100395
8	Sensor PNP Quick Disconnect M12	100388	100388
9	M12 Cable, Quick Disconnect (Cable only)	100389	100389

Front Control Panel



Item	Description	XM-1	XM-20v
1	XM-1 Blue Push Button	100413	100413
2	XM-1 Green Push Button	100412	100412
3	XM-1 Yellow Illumination Push Button	100416	100416
4	Green Ready Light	112052	112052
5	Knob, Speed Pot	100407	100407
	XM-1 10K Speed Pot	100418	100418
6	Thumbwheel Switch Single	100241	100241
7	Red Stop Button	100414	100414
	Front Panel Controls XM-1, Assembly	100227A	100227A
	XM Feeder Push Button KIT - Includes; (1) 800FP-F3 green flush (1) 800FP-F6 blue flush (1) 800FP-LE4 red extended illum. (1) 800FP-LF0 amber flush illum. (3) 800FPX10 N.O. Contact w/mount (1) 800FPX01 N.C. Contact w/mount (1) 800FPP3 green pilot operator (1) 800FALP plastic latch (1) 800FN3Y yellow LED (1) 800FN3R red LED (1) 800FN3G green LED	100883	100883

Rear Control Panel



Item	Description	XM-1	XM-20v
1	16-pin square flange receptacle (pin)	112040	112040
2	4-pin square flange receptacle (socket)	112039	112039
3	Cor Comm Power Outlet	100243	100243
4	Slide Switch	100242	100242

SECTION 6: ACCESSORIES AND AFTERMARKET OPTIONS

Carriage Jig

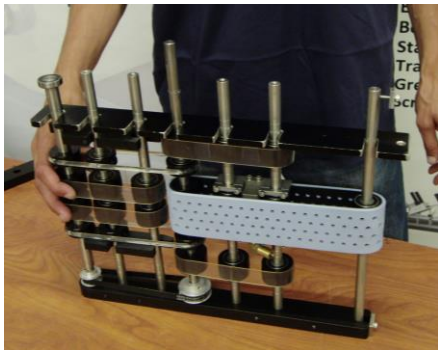

The Carriage Jig is a tool designed to help you change Xtreme XM feeder belt in a matter of minutes. Simply

remove the carriage holder, swap out the belts, and use the Carriage Jig to hold all the shafts in place and slide the carriage holder back in place...effortlessly!



36" Feeder Hopper Extension



Xtreme XM feeders come standard with up to 20" product stacking. Maximize product stacking with 36" feeder hopper extensions. Great for thicker products! (XM-1 shown left)

Right Side Feeder Control Panel

Superior-PHS adds the versatile left or right feeder control panel option depending on your production floor space/setup. Operators can avoid walking around any obstacles to reach the control panel. (Shown: XM-1 left, XM-12HS right)



XM-100 Bulk Loader



If you're looking to get more stacking capability in your feeder, the XM-100 Bulk Loader is designed

to off-set the vertical stacking weight of your product by automatically delivering product horizontally to the feeder hopper. Product can be stacked 6-ft horizontally and is great for thick products and bulk quantities. Up to 12" and 20" wide product feeding (XM-100 and XM-200 respectively).

Vacuum Extension

Add vacuum assist feeding for scanning, reading, printing, and labeling applications. Product is accurately and consistently fed with a secure hold



Wedge Rail Extension Kit

Required for products longer than 12"L. Designed to support longer product stack height and feed during transit. Available in two sizes: products up to 18"L and products up to 27"L.

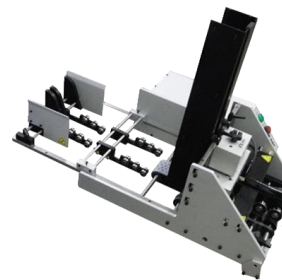

Adjustable Mounting Stand



Designed with locking swivel casters and low-toe profile for mobility on the production floor. Available in 30-40" adjustable and 40-50" adjustable heights. P/N 100966

Victory BD Dropper



Eliminate the need for off-line product counting and batching. Add a Victory Dropper inline to automate batching and stacking of product over an existing flighted/lugged conveyor. A Victory Dropper automatically drops counted stacks onto the moving

conveyor. Available in Bombay, Shutter, Retractable, and Rotary Star Wheel™ styles.

Hopper Hold Down



The Hopper Hold Down is a great accessory to maximize stack height by controlling the integrity of the stack and increase even feeding performance. P/N 100881

Inline Reverse Tray

Easily mounts over existing flighted/lugged conveyors for inline batching. The tray catches up to 1/4" stacks as it's pulled into the pocket by the moving conveyor lug. A cost-effective option for inline batching.



XM Batching Tray



Designed to accumulate batch counted products in neat stacks for manual removal. Easily adjusts to product sizes - the perfect semi-automated counting solution.

Available in three sizes: products up to 12", 20", and 30" wide.

Vacuum Pump



All Xtreme XM feeders come with a vacuum assist belt and manifold. Adding a vacuum supply while feeding product aids in product separation and consistent feeding performance. (Image

shown is for reference purposes only. Not the actual pump.)

Inline Mounting Kit



Mount feeder inline on any flighted/lugged conveyor top - used in lieu of the adjustable mounting stand. Easy adjust and quick detach.

Trigger Echo feature



Important, please read before making any connections or powering on the feeders.

Description

The Trigger Echo feature is designed to allow users to “daisy-chain” several feeders together for the trigger signal. When the trigger signal is received by the first feeder, either via photo-sensor or externally from a host system, an output signal, Trigger Echo, is sent to the next feeder, and repeats down to the last feeder. This feature is standard on the XM-1. For ease of integration, an optional cable assembly is available specifically designed for this feature.

Optional Flight Echo Cable Assembly - Detail

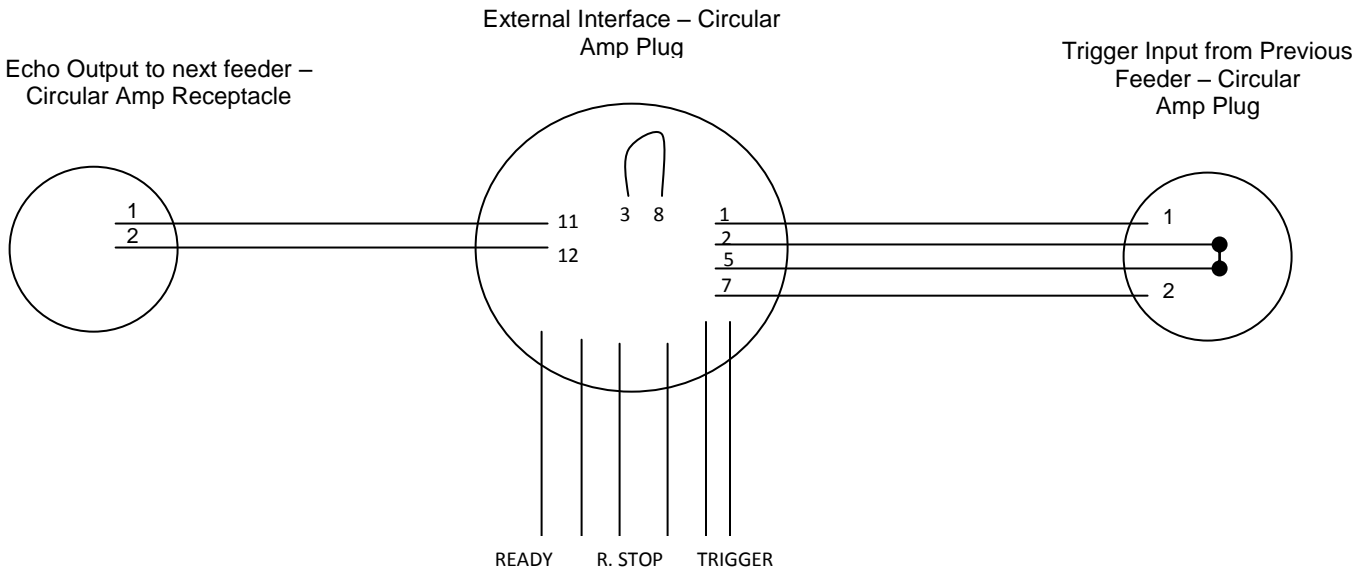

Each feeder part of the echo group powers the signal from the previous feeder. Example, 3 feeders on a line, feeder 2 powers the echo from feeder 1, feeder 3 powers the echo from feeder 2. Feeder 1 uses the photo sensor.

Trigger Echo feature continued...



IMPORTANT NOTES

When powering on the feeders, you should always start with the first feeder, then the second, and so on. If not, false triggers to the feeders may occur during power up.

If not all feeders are being used but are still part of the group, each feeder needs to be powered on. Do not put the feeders not being used into Ready mode. Leave them in power on mode (represented by solid reset lamp). This must be done to make sure the echo signal is sent all the way to the last feeder.

If a feeder is to be removed from the line, you must disconnect that particular cable assembly from the others and join the cables of the feeders before and after the removed feeder for the Echo routine to make it to the last feeder. If several feeders are going to be removed, the Trigger In and Echo Out cables may not be long enough to connect to each other. Custom extension cables are available at additional cost. Please supply length(s) required.

OPTIONAL: Burn-Thru Double Sheet Detector

The optional Burn-Thru Double Sheet Detect feature provides added security to applications where all sheets fed need to be accounted for. Along with the standard Miss Detect feature, the optional Burn-Thru Double Sheet Detect feature ensures that only one product is being fed at a time.

Setting the Double Sheet Detect feature

1. Move the Double Detect Enable/Disable Toggle switch located on the feeder rear panel to the Enable position.
2. Manually insert 2 paper sheets into the discharge of the feeder between the upper and lower double detect sensor.
3. Open the cover on the Amplifier, push the Set button twice. On second time, display will flash.
4. When done flashing, Double Detect is set. Close and secure the cover to the amplifier and remove the paper sheets from the discharge of the feeder.
5. To test for verification, set up product in the feeder (see set-up procedure) and cycle a few singles through. Open up the separator a bit to allow a double to advance to the sensor, if set correctly, the feeder will stop and blink the RESET lamp at the Double Detect medium speed.
6. To clear the double detect, remove the paper sheets from the feeder and press the reset button, the feeder will return to ready mode.

Note: You cannot cycle the feeder when there is a double. It will stop each time. You can Jog the double out or pull it out by hand.

7. If necessary, readjust the separator before loading or feeding any more sheets.
8. *Please note: Sensor needs to always be set to Dark-on mode. Refer to sensor instruction sheet that came with the feeder if you're not sure.*

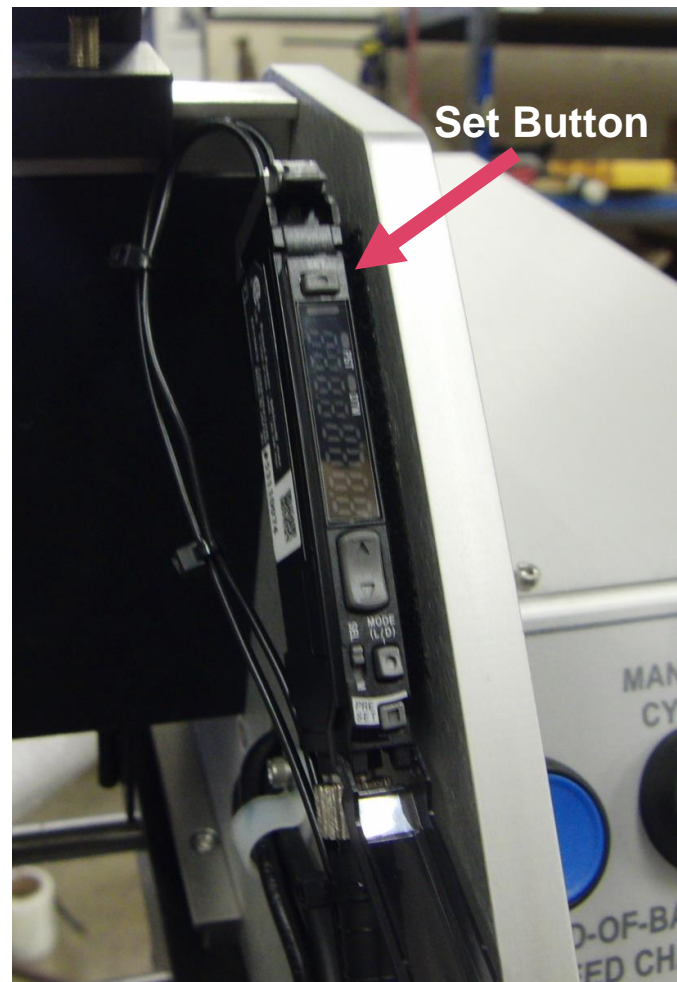

SECTION 7: MAINTENANCE

Please remember that all maintenance and service to the XTREME Versatile Feeding Solution should only be performed by qualified technicians. Always disconnect power before attempting any maintenance or service procedure.

Belts

Over time, you will notice “build-up” on the feed and discharge belts and the separator rollers. This is normal and is usually from the dust, finish, or coating normally on the products fed. Regular cleaning of the belts and rollers will extend their life.

Belts, pulleys, and rollers should **only be cleaned with Isopropyl Alcohol**.

A good practice is to clean the belts and rollers weekly. If running UV or Aqueous coated materials, daily cleanings are recommended.

Sensors

Wipe sensors with a clean lint free cloth to clear any dust build up. Recheck the adjustment of the sensors if they were moved during cleaning and reset.

Machine

It is always best to keep machines clean. Keep them dusted and free of spills.

Always inspect your machine for loose or damaged items and replace them immediately.

Separator Assembly Removed from Feeder

To remove the separator assembly, power off the feeder, remove all product from hopper, and disconnect the motor cable from the top plate connector. Then, remove the 4 screws that fasten the top block to the cross plate. Each roller has two set screws (one fastens to the flat on the shaft). Loosen the set screws of the inside rollers and slide them to the outside rollers. Retighten the set screws making sure one of them is fastened to the flat on the shaft.

Reinstall the separator assembly and refer to the Product Guide for product set up. Note: since the rollers will now be adjusted slightly below the surface of the belt, the adjustment will be lower than previous setting.



How to Change Xtreme XM Feeder Belts

Remove all power from the feeder before changing belts



Figure 1: Remove control cabinet cover. Remove front panel.



Figure 2:



Figure 3: Remove front driver sprocket

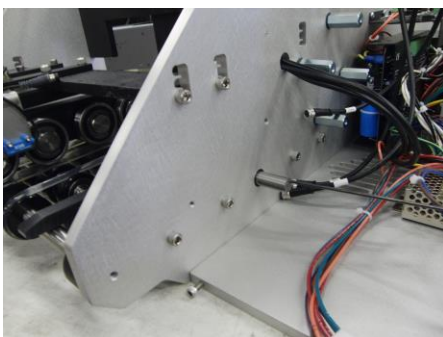

Figure 4:

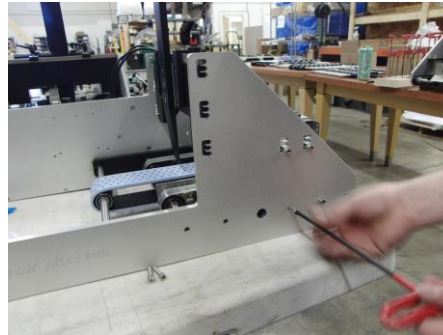

Figure 5: Remove all screws on the right feeder panel. Note: top screws are 3/4", bottom screws are 1"

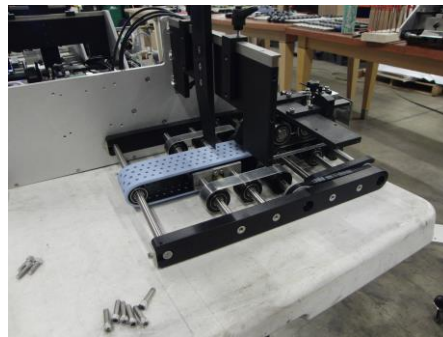

Figure 6



Figure 7: Remove top 2 screws on left panel to completely remove hold down assembly.

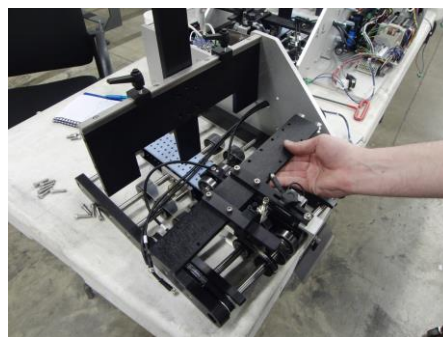

Figure 8: Remove hold down assembly.

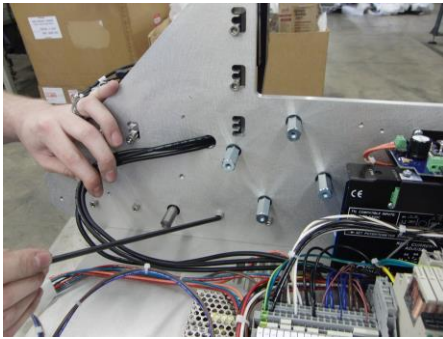

Figure 9: Remove bottom 4 screws on the left panel to release the carriage.

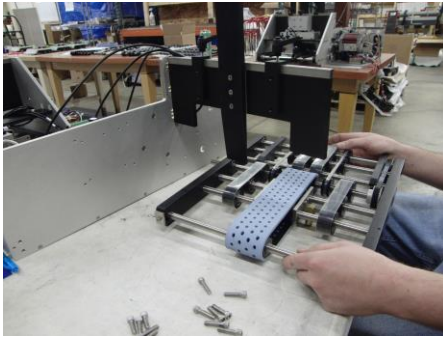

Figure 10

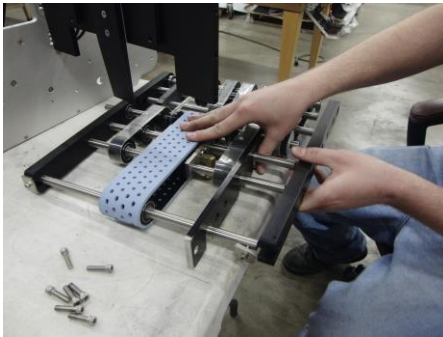

Figure 11: Use the Carriage Jig (sold separately) to hold all shafts in place. Slide the right side carriage holder off the carriage.

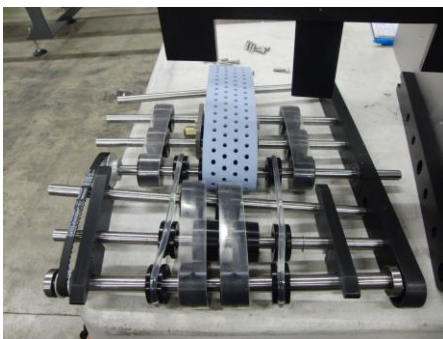

Figure 12: Referencing this image, remove belts and replace from right to left.

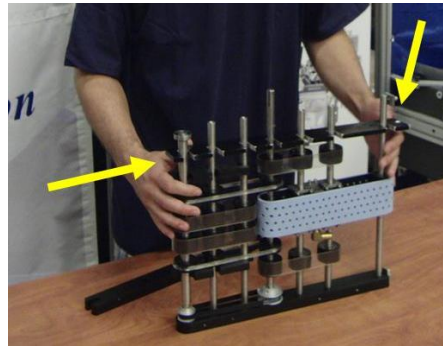

Figure 13: Use Carriage Jig to hold all shafts in place and slide carriage holder back in place.



Figure 14: Perform steps 1-11 in reverse order to reassemble.

NOTE: DO NOT OVERTIGHTENED THE FIRST SCREW ON EITHER SIDE OF THE FEEDER.

There is supposed to be a gap between the screw and the panel. Over tightening will cause resistance, or locking up, of the lead shaft.

SECTION 8: OPERATIONAL TROUBLESHOOTING

Difficulty	Possible Cause	Proposed Solution
No AC power to the unit	<ol style="list-style-type: none"> 1. On/Off switch in Off position (O). 2. Power cord loose or not plugged into AC source. 3. Power cord loose or not plugged into unit. 4. Blown Fuse(s) 	<ol style="list-style-type: none"> 1. Move switch to On position (-). 2. Check connection to AC source. 3. Check connection to unit. 4. Replace fuse(s) (consult technician)
Belts are turning but product is not feeding	<ol style="list-style-type: none"> 1. Separator not properly adjusted. 2. Hopper side guides are too tight. 3. Interlocking or adhered product. 4. Static 5. Product stack-height too low or too high. 6. Slick feed belt. 	<ol style="list-style-type: none"> 1. Review separator setup instructions. 2. Review hopper setup instructions. 3. Check product. 4. Consult with a qualified technician. 5. Review Operation, Step 1 instructions. 6. Consult with a qualified technician, clean belt.
Double feeding	<ol style="list-style-type: none"> 1. Separator not properly adjusted. 2. Wedge support not properly adjusted. 3. Worn separator rollers. 4. Separator rollers spin freely. 	<ol style="list-style-type: none"> 1. Review separator setup instructions. 2. Review wedge support setup instructions. 3. Consult with a qualified technician, replace rollers. 4. Consult with a qualified technician, check separator drive belt and pulleys.
Jamming or skewing	<ol style="list-style-type: none"> 1. Improper setup. 2. Interlocking or adhered product. 	<ol style="list-style-type: none"> 1. Review setup instructions on Separator, Hopper/Wedge, and Discharge Hold-Down. 2. Check product.
Gate Rollers Not Turning		1. See Additional Setup Information: <i>Rotating Gate</i> .
Feeder Gives Over Count	<ol style="list-style-type: none"> 1. End-of-Batch Speed Change is set \geq Batch Size 2. Sheet sensor photo cell is positioned over a shaft. 3. Batch Count is set incorrectly 	<ol style="list-style-type: none"> 1. Set End-of-Batch Speed Change thumb wheel to less than Batch Size 2. Be sure the photo cell is seeing a gap between product indicated by the light turning on and off as product passes 3. Jog product and check for ≥ 1" gap between products. See setup 4. Contact a technician
Feeder Gives Under Count	<ol style="list-style-type: none"> 1. Batch Count is set incorrectly 2. Photo cell is detecting (a) reflective product, (b) curled product, or (c) a color on a sheet activating a second count. 	<ol style="list-style-type: none"> 1. Change the angle or position of the photo cell 2. Order optional photo cell.

SECTION 9: GLOSSARY OF TERMS

AC INLET MODULE -Provides 115 or 230vac power to the feeder (60or 50Hz). This module has built-in fuse protection and on/off switch.

BATCH SIZE -The Batch Size is represented by a 2-position thumbwheel switch. Adjustment of the thumbwheels is from 00 to 99. The batch size represents the number of pieces that will be dispensed for each cycle of the feeder. If the thumbwheels are set to 01, one piece will be dispensed when the cycle is initiated. If set to 99, ninety-nine pieces will be dispensed when the cycle is initiated. The Sheet Detect Sensor is used to count trailing edges to ensure product count. It also acts as the “stop” for each cycle. When the batch size is set to 00, the feed belts will turn continuously when the feed cycle is initiated and will continue turning until the stop button is pressed (continuous mode). Changes to the batch size cannot be accepted during a feed cycle (including continuous run). Changes can only be accepted during all other conditions.

CYCLE -The Cycle pushbutton is a momentary pushbutton that will send a signal for the feeder to perform a complete feed cycle. The ## setting on the batch size thumbwheels will determine the number of pieces to be fed for each cycle. The Cycle button is Blue in color. This function only works when the feeder is in ready mode.

DOUBLE DETECTION This device is used to sense the presence of multiple pieces when only one should be present. Detection of a “double” feed will stop the feeder and take it into a fault condition. The fault condition is represented by a MEDIUM speed blink (repeating ½ second on, ½ second off) on the fault/reset pushbutton. In this condition, the feeder stops and the ready signal is dropped (green lamp off). The operator must physically remove the double from the feeder in order to reset the condition. Once the material is removed, the fault can be reset by pressing the fault/reset pushbutton thus returning the feeder to ready mode (green lamp on). The Double Detector device will be located (mounted) toward the end of the discharge just prior to exiting. A slide switch (enable/disable) allows the user to use this feature or not.

END-OF-BATCH -This feature is represented by a one-position thumbwheel and a variable speed adjusting dial. End-of-Batch is used to either speed up or slow down the end of the batch. The # on the thumbwheel represents the piece that the speed change will take place on. If the batch size is set to 20 and the speed change is set to 1, the speed change will take place after piece 19 has been dispensed. If set to 2, the change will take place after piece 18 has been dispensed, and so on. Activated on leading edge of piece. If set to zero, no speed change will take place. The # on the thumbwheel must be at least one digit smaller than that displayed on the batch size thumbwheels. If not, no speed change will occur. The independent speed setting will be used to either slow down or speed up based on its position compared to the main speed dial.

EXTERNAL INTERFACE - Discreet signals used to communicate out and in with other equipment. Signals include a “ready” output, “trigger” input, “remote stop” input, and “trigger echo” output.

FAULT/RESET -Lamp (orange) and pushbutton combo. Used to provide a visual clue to feeder errors and to provide a reset of those error conditions. The conditions are as follows:

Miss Detect – Slow Blink (1-second on, 1-second off – repeating)

Timeout – Fast Blink (1/16-second on, 1/16-second off – repeating)

Double Detect (Option) – Medium Blink (1/2-second on, 1/2-second off – repeating)

Stop – Solid on with a solid on stop lamp

Power up – Solid on with no other lamps

- JOG** -The Jog pushbutton functions so that when depressed and held, the belts turn. When released, the belts stop. This feature allows the operator to automatically advance product through the feeder each time it is pressed and held. The jog speed is equal to main speed setting. This feature operates during setup mode and ready mode.
- MISS DETECTION** -Miss detect is represented when more than one trigger signal is sent prior to completion of feed cycle. A selector switch allows the user to enable or disable miss detect. When enabled, a miss will stop the feeder, drop the green ready lamp, and slow blink the fault/reset lamp (1-second on, 1-second off – repeating). Pressing the fault/reset pushbutton will clear the fault lamp and illuminate the green ready lamp, putting the feeder back into ready mode. When this feature is disabled, the feeder will not stop when a miss feed is detected. The miss detect feature is ignored when the bath size is set to 00.
- READY LAMP**-Lamp only (green). This indicates a visual clue that the feeder is ready to receive trigger signals and that there are no fault conditions. This signal is N.C. when on and changes to N.O. when off.
- SHEET SENSOR** -The sheet sensor is located in the discharge of the feeder and mounted on an adjustable mechanical arm. It will act as the “cycle stop” and will double as a counter when batch counting is used. The standard sensor is a light-on, diffuse reflective. This sensor is activated by leading edge.
- STOP** -Pressing the Stop button will automatically put the feeder into Stop Mode indicated by a solid red lamp located in the stop pushbutton. In addition, the green ready lamp will turn off and the orange fault/reset lamp will illuminate solid. Pressing the fault/reset pushbutton will remove the feeder from stop mode and return it to ready mode thus turning the stop and fault/reset lamps off and the green ready lamp on.
- TIMEOUT** -The timeout feature is a software based feature that monitors “out-of-product”. If a cycle signal is initiated, the software will monitor the change in the sheet detect sensor. If no change occurs (either blocked or unblocked) for 2 consecutive seconds, the feeder will go to timeout and be represented by a FAST (repeating 1/16 second on, 1/16 second off) blink of the fault/reset lamp. Pressing the fault/reset pushbutton will clear the fault and return the feeder to ready mode. This feature is ignored when batch size is set to 00 (continuous mode). A slide switch (enable/disable) allows the user to use this feature or not.
- TRIGGER DELAY** -This feature is a variable dial position with stops on both ends. This feature (when used) will add delay to the trigger signal coming from the trigger sensor or externally through the I/O interface. The delay range is 0.0 seconds up to 2.0 seconds. The settings are in increments of 1/10th second. 0.0 represents no delay and 2.0 represents full delay.

TRIGGER SENSOR -Also known as Flight Sensor. This sensor is used to trigger the feeder when an object passes through the detect range of the sensor. As an object passes through the detect range, the trigger sensor signal will cause the feeder to perform a feed cycle. The cycle will only take place if the feeder is in ready mode. More than one trigger prior to completion of a feed cycle will be represented as a Miss-Feed fault. The standard sensor is a light-on, diffuse reflective sensor. The Trigger sensor is activated by leading edge.

Signal Definitions:

Ready Output – Signal is normally low. Goes high when asserted. This signal is an indicator to other equipment that the feeder is ready to receive trigger signals.

Trigger Input – Signal is normally low. Goes high when asserted. This signal would typically come from an external source to cycle the feeder vs. using the trigger photo-sensor. Signal in should be a momentary contact closure, minimum 50ms.

Remote Stop Input – Signal is normally high. Goes low when asserted. This feature allows the user to wire in to other equipment stop circuits. Signal in should be a momentary contact closure, minimum 50ms. Signal from host can also “hold” this signal to prevent operators from resetting the feeder if other parts of the system are not ready.

Trigger Echo Output – This signal is normally low. Goes high when asserted. When the main trigger of the feeder takes place either by the cycle pushbutton, trigger photo-sensor, or through the Trigger Input I/O, this signal will go high during the duration of the main trigger signal and return to low. This feature allows several feeders to be triggered by one trigger device.

SECTION 10: WARRANTY

WARRANTY:

SUPERIOR – PHS LIMITED WARRANTY

Superior Paper Handling Solutions, Inc. (Superior – PHS) warrants this product to be free from defects in materials and workmanship, when used under recommended operating conditions, for a period of one year from the date of original shipment.

If you discover a defect during the warranty period, please notify the distributor from whom you purchased this product, who will arrange for the replacement parts to be sent to you. Defective parts must be returned to Superior – PHS for credit on replacement parts. Shipping and labor costs are not included in this warranty. If the defect is not field-repairable, and if you return it to Superior – PHS during the warranty period, Superior – PHS will, at its sole option, repair or replace this product, at no charge to you other than shipping charges to and from the facility in Minneapolis, Minnesota.

If you return this product to Superior – PHS for warranty repair or replacement, please attach to the returned product your name and your company's name, address, telephone number and fax number; a description of the problem; and a copy of the bill of sale or invoice that shows the appropriate serial number for the product. All returns must be accompanied by an authorized Superior – PHS Returned Goods Authorization (RGA) number. An authorized RGA number can be obtained from the Superior - PHS distributor from whom you purchased this product.

This warranty applies only to products manufactured by Superior - PHS. This warranty does not apply if the product has been damaged by accident, abuse, misuse, neglect, improper maintenance, misapplication, or as a result of being attached to equipment not supplied by Superior - PHS; if the product has been modified without the written permission of Superior - PHS; or if the product's serial number has been removed or defaced. This warranty further does not apply to the failure of any rubber-based or consumable components including, but not limited to, rollers, bearings, belts, fuses, or bulbs.

ALL IMPLIED WARRANTIES INCLUDING WITHOUT LIMITATION THE IMPLIED WARRANTY OF FITNESS FOR A PARTICULAR PURPOSE AND THE IMPLIED WARRANTY OF MERCHANTABILITY ARE HEREBY DISCLAIMED.

Superior - PHS is not responsible for special, incidental, or consequential damages resulting from any breach of warranty or under any other legal theory, including lost profits, downtime, goodwill, or damage to or replacement of equipment or property.

This warranty and the remedies set forth above are exclusive and are in lieu of all others, oral or written, express or implied. There are no warranties that extend beyond the description on the face hereof. No Superior - PHS employee, distributor, or agent is authorized to make any modification, extension, or addition to this warranty.

Notes
