

# Maxim Operator's Manual

---

Models: RX-9s, RX-12c, RX-12cs

PATENT PENDING



## TABLE OF CONTENTS

CONTENTS:.....	2
OVERVIEW & SPECIFICATIONS.....	3
ASSEMBLY INSTRUCTIONS.....	4
FRICTION FEEDING OVERVIEW.....	5
PRODUCT SETUP.....	6
Loading Product.....	6
RX-9s and RX-12cs for STAGING applications:.....	6
RX-9s and RX-12c for CONTINUOUS applications:.....	7
Correcting for Product Skew.....	7
Operating Stack Height.....	7
COMPONENTS & PARTS LIST.....	9
RX-9s.....	9
RX-12c / RX-12cs.....	10
ELECTRICAL SCHEMATIC.....	11
RX-9s.....	11
RX-12c.....	12
RX-12cs.....	13
ACCESSORIES AND AFTERMARKET OPTIONS.....	14
WARRANTY.....	15
NOTES.....	16

Thank you for purchasing your Maxim RX Friction Feeder. Enclosed please find simple step-by-step instructions to help you quickly assembly your product. Before you begin, we recommend that you follow the steps below:

1. Please read the instructions thoroughly
2. Identify all parts, inspect that all items are received and there is no damage from shipping.
3. You will need the following tools: 1/8" and 5/32" allen wrench, 3/8" wrench

**CONTENTS:**

**RX-9s contents below**



RX-9s Chassis with staging sensor assembly



Hopper Assembly



(3) Product Wedges



Spring Clips, Inserter (standard on RX-9s and RX-12cs after 6/15/15)  
 Power Cord

**RX-12c contents below**

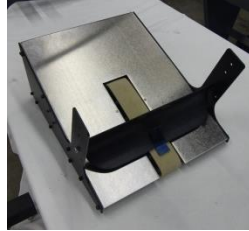

RX-12c Chassis



Hopper Assembly



(2) Product Wedges,  
 (2) Small Product Wedges



Low Profile Roller Support Wedges (standard after 6/15/15)

Power Cord

**RX-12cs contents below**



RX-12cs Chassis with staging sensor assembly



Hopper Assembly



(2) Product Wedges,  
 (2) Small Product Wedges



Low Profile Roller Support Wedges (standard after 6/15/15)  
 Spring Clips, Inserter (Shown left)  
 Power Cord

## OVERVIEW & SPECIFICATIONS

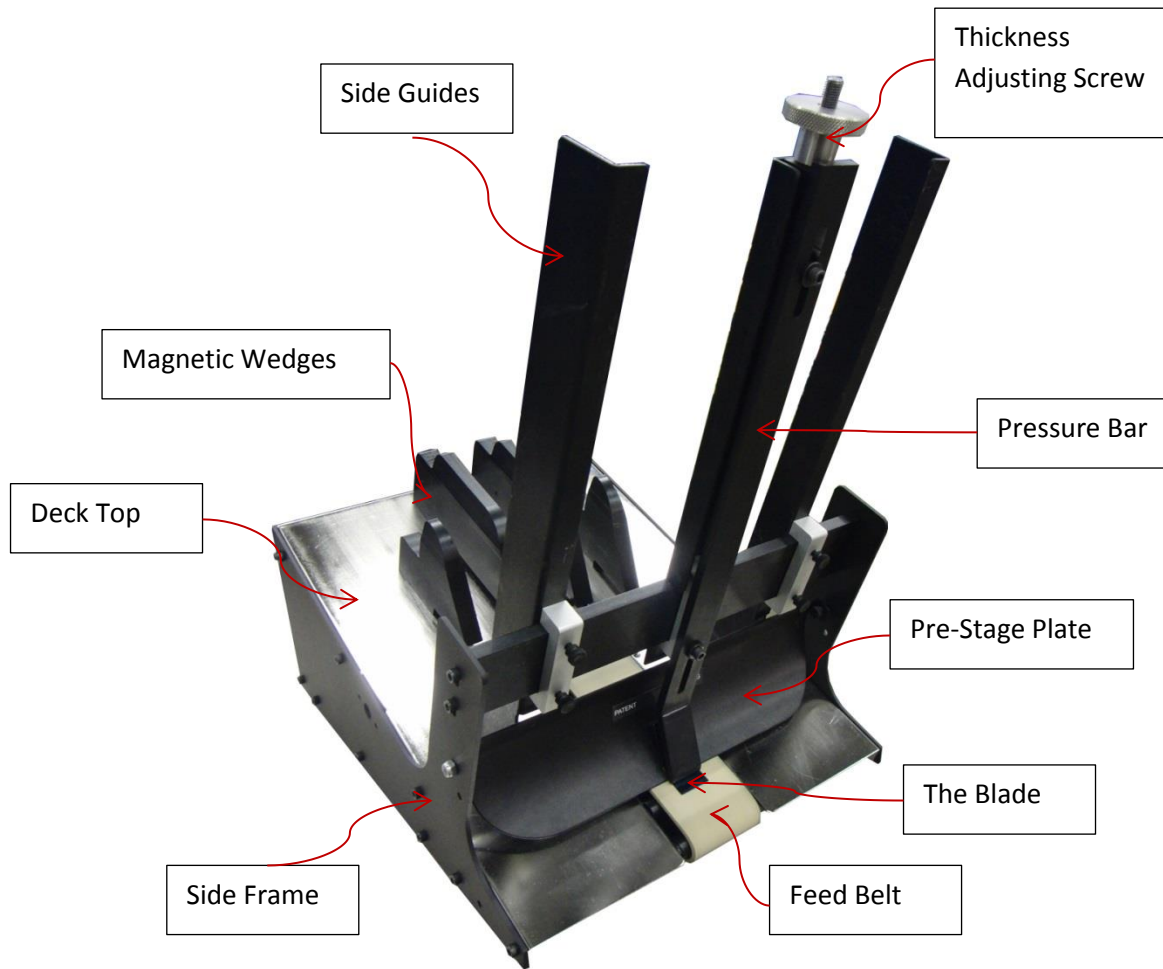

**PRODUCT SIZES:**

RX-9s: 2.5"W x 3.5"L – 8.75"W x 7.5"L  
RX-12c/cs: 2.5"W x 3.5"L – 12"W x 12"L

**PRODUCT THICKNESS:**

.004" - .375"

**SPEED:**

400 ft./min, DC motor

**WEIGHT:**

RX-9s: 23 lbs  
RX-12c/cs: 29 lbs.

# ASSEMBLY INSTRUCTIONS

1. Remove the 4 screws on the Hopper Assembly

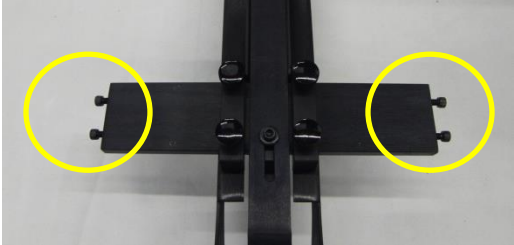

2. Loosen or remove the Thickness Adjusting Screw



3. Insert the Hopper Assembly between the chassis side frames. Be sure the pressure bar on the hopper is positioned over the Blade

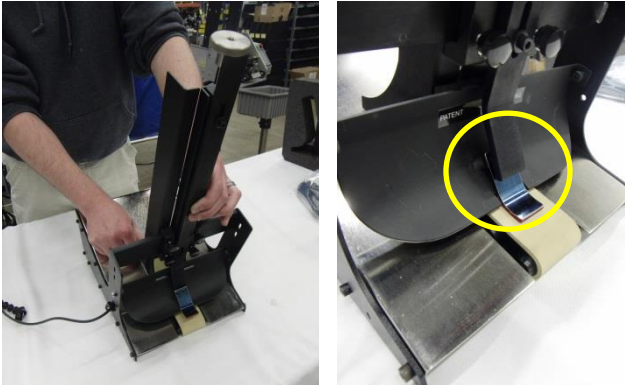

4. Mount the Hopper Assembly to the Chassis side frame with the 4 screws using a 5/32" allen wrench. Position the Hopper Assembly in the screw slots with 1/8" clearance above the chassis decktop.

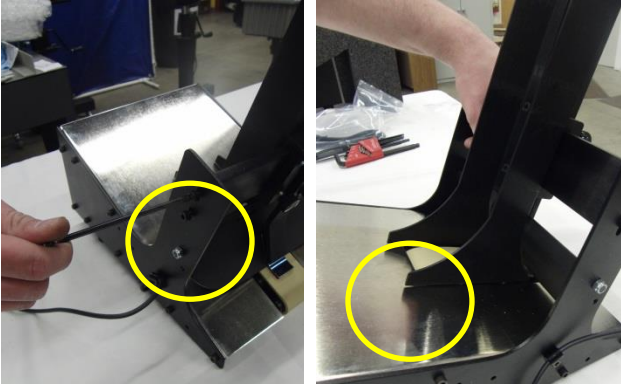

5. Place the magnetic Product Wedges on the chassis decktop. These will be used to support and lift your product.

 **The wedges contain powerful magnets. Do not place your fingers between the magnets and any metal object.**



**FOR RX-9S AND RX-12CS MODELS ONLY**

6. Remove the screw and nut from the Sensor Assembly. Mount the Sensor Assembly to opening in the Chassis side frame.

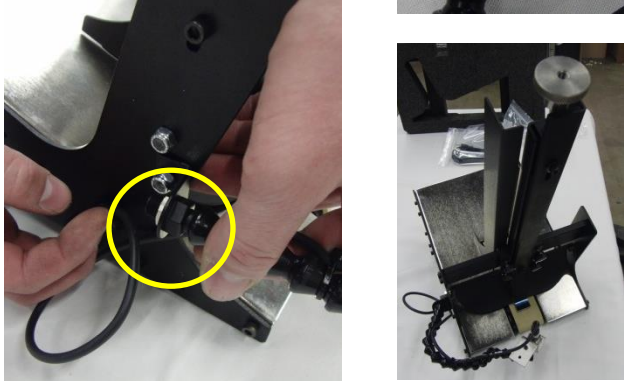

## FRICITION FEEDING OVERVIEW

**IMPORTANT:** *If you are unfamiliar with friction feeding technology, it will be extremely beneficial to review the following section.*

**Friction** = surface resistance, of one object against another, to relative motion.

**Feeder** = a device that feeds product

**Watch video demo:** [vimeo.com/superiorphs/feederbasics](https://vimeo.com/superiorphs/feederbasics)



Friction feeding technology is used to separate and feed objects through the motion of friction. A stack of product is placed into the hopper and separated by pulling the bottom piece through the feeder against the static friction weight of the product on top of it.

There are three basic guidelines for using friction feeding technology:

1. **Can the product be fed?** Take two pieces of your product and place them together. If they can slide apart, they can be fed. Good product candidates for friction feeding include card stock, cards, envelopes, paper, chip board, corrugate material, and other flat surface materials.
2. **Does the product easily mark or chip easily?** Some products mark easier than others so this will need to be tested.
3. **Does the product interlock when separating?** Some irregular shaped and die cut products may interlock when feeding and rip the product.

If any of these steps cannot be achieved, you will need to use something other than a friction feeder to separate your product.

The primary goal in friction feeding is to create a gap between each piece of product. For the Maxim RX-9s, RX-12c, and RX-12cs, the primary goal is to **initiate product separation**. You will NOT see a gap between pieces on these models.

**\*\*\*FOR THESE MODELS, PRODUCT SEPARATION DOES NOT OCCUR ON THE FEEDER OR UNDER THE BLADE\*\*\***

In staging applications, the goal is to create enough product separation under the Blade that some other object, such as an inserter swing arm, robotic arm, or operator, can grab the leading piece and pull it out.

In continuous applications, the goal is to create enough separation so that the feeder can feed onto another object, such as a vacuum conveyor, that is running *faster* than the feeder. The conveyor running faster than the feeder will pull the product faster and create a gap *on the conveyor*.

This will be further detailed in the Product Setup section.

## PRODUCT SETUP

**Watch video demo:** [vimeo.com/superiorphs/rxproductsetup](https://vimeo.com/superiorphs/rxproductsetup)

### **Loading Product**

1. Raise the Pressure Bar off the feed belt by turning the Thickness Adjusting Screw counter-clockwise.
2. Center one piece of product under The Blade and loosely tighten down the Pressure Bar by turning the Thickness Adjusting Screw clockwise. Be sure the product is centered over the feed belt to prevent skewing.
3. Fan out 1" of product and load into the hopper. Be sure the stack of product is perfectly fanned out and follows the curve of the Pre-Stage Plate.
4. Position the Magnetic Wedges to produce a little lift on the back end of the product. The RX-12c/cs come with 2-**Small Product Wedges** that are the longer wedges. These are notched on the bottom so they can be placed over the feed belt to support shorter products. In general, for flimsy products longer than 6" to 8", place the **Roller Support Wedges** (shown right) under the product stack to help support the weight and aid in product separation.
5. Be sure the product is supported evenly to reduce product skewing as it's fed.  
*NOTE: the amount of lift is product dependent. Use more lift for flimsy products, less for rigid products.*  
*NOTE 2: more lift equals more separation, less lift equals less separation.*
6. Adjust the Side Guides to 1/16" to 1/8" of clearance on either side of the product so it isn't pinched.
7. Fan out 2-3" of product and place it in the hopper. Again, be sure the stack is perfectly fanned out and hugging the curve of the Pre-Stage Plate.
8. Stack height above the Pre-Stage Plate does not need to be fanned out. Be sure your product is jogged square before loading.

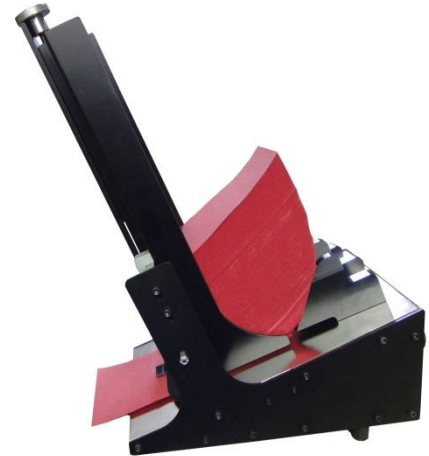

### **RX-9s and RX-12cs for STAGING applications:**

The following instructions are general starting points and can be adjusted for your application.

1. Position the staging sensor to approximately 1" past the feed belt at the nose of the feeder. This staging sensor has a 4" range and will stage each piece of product up to this sensor.
2. Set the speed dial between 3 and 4 and Power 'On' the feeder.  
*NOTE: The feeder will stage the product up to this sensor. If product continues to feed past the sensor, it is out of range from the leading piece and will need to be adjusted to detect the piece.*
3. Simultaneously, pull the leading piece out of the feeder while



adjusting the Thickness Adjusting Screw to your desired pressure. Two pieces overlapping under The Blade is perfectly normal. Remember, all you need is enough separation so that something else can grab the leading piece and pull it away.

4. Position the Staging Sensor to stage the product to your desired position.
5. Use the Spring Clips on mailing inserters and jumbo inserters to create a pinch point for the product to feed in to.

***RX-9s and RX-12c for CONTINUOUS applications:***

1. Set the speed dial to '0' and power 'On'. RX-12c: be sure the 'Inhibit' is also 'Off'.
2. Simultaneously, slowly increase the speed while adjusting the Thickness Adjusting Screw until you achieve enough pressure produce a steady stream of product.
3. Power 'Off' the feeder between each use.
4. RX-12c - if you are using a standard I/O Inhibit option:
  - a. Turn the Inhibit 'On'.
  - b. Feeder will run unless pins 1 and 4 on the 4-pin I/O connector are shorted together.



***Correcting for Product Skew***

On Maxim RX models, two factors contribute to skewing:

1. Uneven product weight distributed over the feed belt:
  - a. Be sure the weight of your product stack is evenly distributed over the feed belt. Position the magnetic wedges under and around your product stack to help distribute the weight.
  - b. In general, whichever corner of your product is leading first usually means that side of the product has more contact with the feed belt and is pulling faster. Using micro-adjustments with your wedges, lift that side of the product off the belt or lower the other side.
2. Product not centered in the hopper:
  - a. For symmetrical products, be sure the product stack is centered over the feed belt and adjust the side guides to help center your product.
  - b. For asymmetrical products, be sure the stack is positioned over the feed belt to distribute the product weight evenly. This is especially true with poly bags and other uneven products.

***Operating Stack Height***

Operating stack height refers to the amount of product in the hopper. This will vary depending on the weight and rigidity of your product. While the feeder has a maximum stack capacity of 16", your product may not allow for that. Heavy-thin products, such as paper sheets, will have a lower operating stack height around 2"-5", while lighter-rigid products, such as envelopes, may run at full 16" capacity. The greater the weight, the greater the friction and force needed to separate the product.



***NOTE: Overtightening the Blade and creating too much pressure to try and separate your product can damage the feeder by creating too much resistance on the motor and prematurely wearing down your belts, Blade, and other consumables.***

Instead, use the wedges to lift heavier products off the feed belt to aid in separation and reduce friction, and/or reduce your stack height. There is no exact formula to determine your operating stack height. For maximum results, use trial-and-error to find your optimal stack height for your specific product type and keep your operating stack height close to that range. You may notice feeding inconsistencies if the operating weight/height of your product stack is not consistent.

# COMPONENTS & PARTS LIST

## RX-9s

ITEM NO.	PART NUMBER	DESCRIPTION	QTY.
1	300505	Side Guide Right	1
2	300506	Side Guide Left	1
4	300564	Threaded SST Knob	1
5	300561	Top Adjustment Block with Rod	1
6	301062	Center Hopper Plate	1
7	390127	Washer Metallic	2
8	390126	Stainless Steel Socket Head Cap Screw 10-32 x .875"	1
9	300552	Cross Bar Support	1
10	300501	Cross Bar Clamp	2
11	390023	Stainless STL Socket Head Cap Screw 10-32 X .750"	1
12	301063	Center Cross Bar Clamp	1
13	300562	Pressure Bar	1
14	390097	Thumb Screw 10-32 X .500"	4
15	300560	Pre Shingle Plate	1
16	400226A/ B	The Blade "TM" 55A/ 70A	1
17	390125	SSTL Shoulder Bolt	2
18	300515	Shaft Idler Dishcharge	1
19	300517	Shaft Idler	3
20	400151	Roller Idler Discharge Assembly	4
22	300518	Roller Drive Rear	1
23	300990	Smooth Feed Belt	1
24	300853	Small Bumper	2
25	301000	Carriage	1
26	301003	Shaft Drive Rear	1
27	300845	Timing Pulley	1
28	300854	Tall Bumper	2
29	100135	Bearing R6	1
30	300520	Bearing Holder R6	1
31	300555	Motor Pan	1
32	300849	90VDC Motor	1
33	300848	Timing Pulley	1
34	300852	Timing Belt	1
35	301007	Side Frame	2
36	301008	Top Deck Pan	1
37	300843	Motor Drive	1
38	300850	Relay	1
39	300851	Power Supply	1
40	100243	CorCom	1
41	300680	Rear Magentic Wedge	3

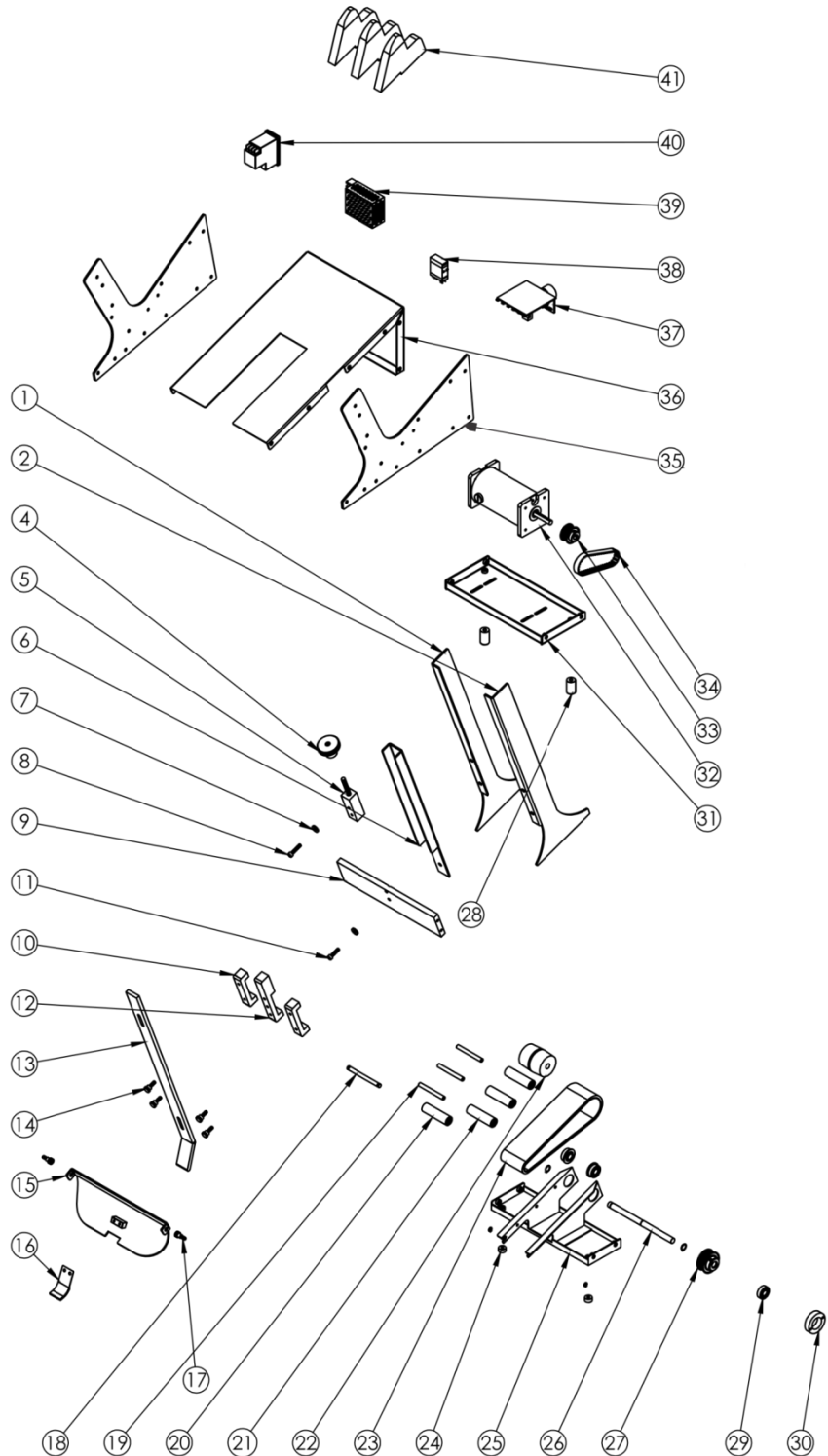

**RX-12c / RX-12cs**

ITEM NO.	PART NUMBER	DESCRIPTION	QTY.
1	400155	2.0 CARRIAGE ASSY *	1
2	300991	2.0 FEED BELT	1
3	300846	DRIVE BELT	1
4	400226A/B	THE BLADE™ (A-55A/B-70A duro)	1

\* When needing to replace a feed belt (Item 2) the carriage Assy (Item 1) can be ordered as an option to ordering the belt alone. A core replacement charge is instituted until the repairable carriage is returned. We inspect all bearings and rollers when a replacement carriage is ordered and the feed belt is new. Call for pricing and procedures.

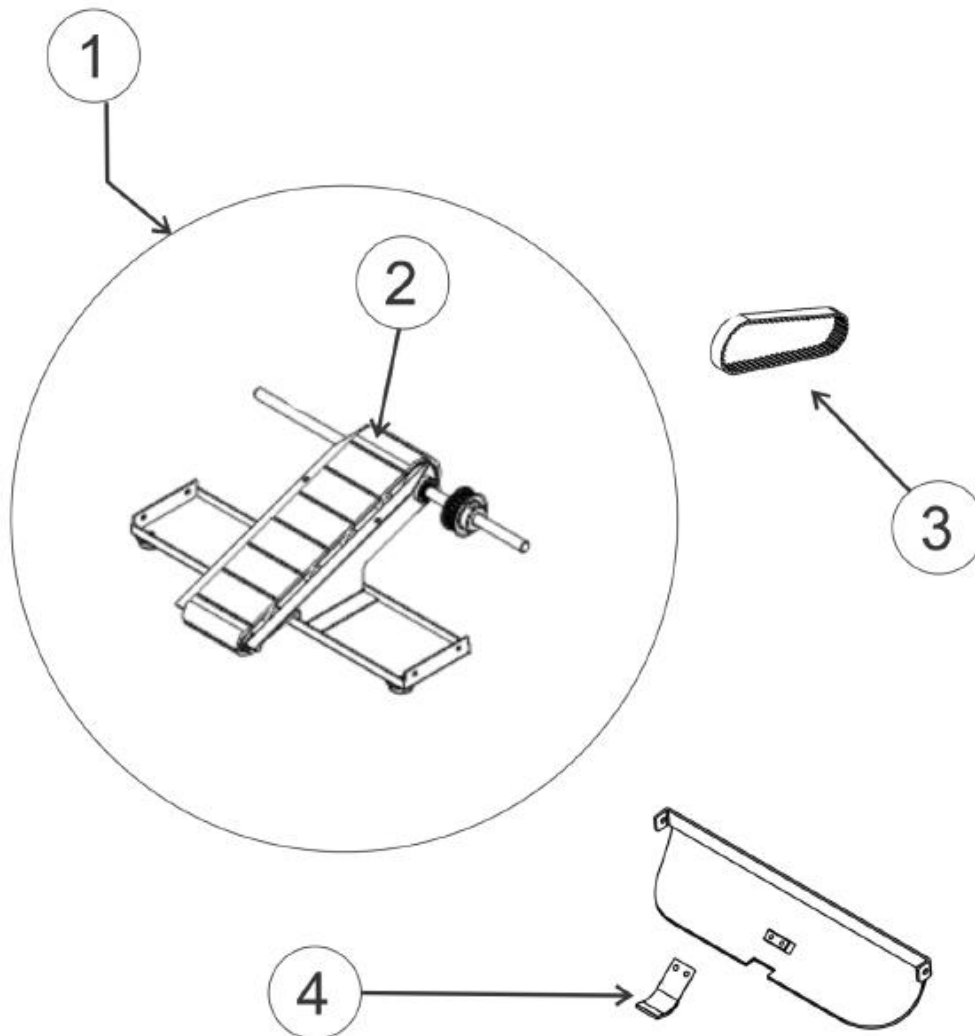

**ELECTRICAL SCHEMATIC**  
**RX-9s**

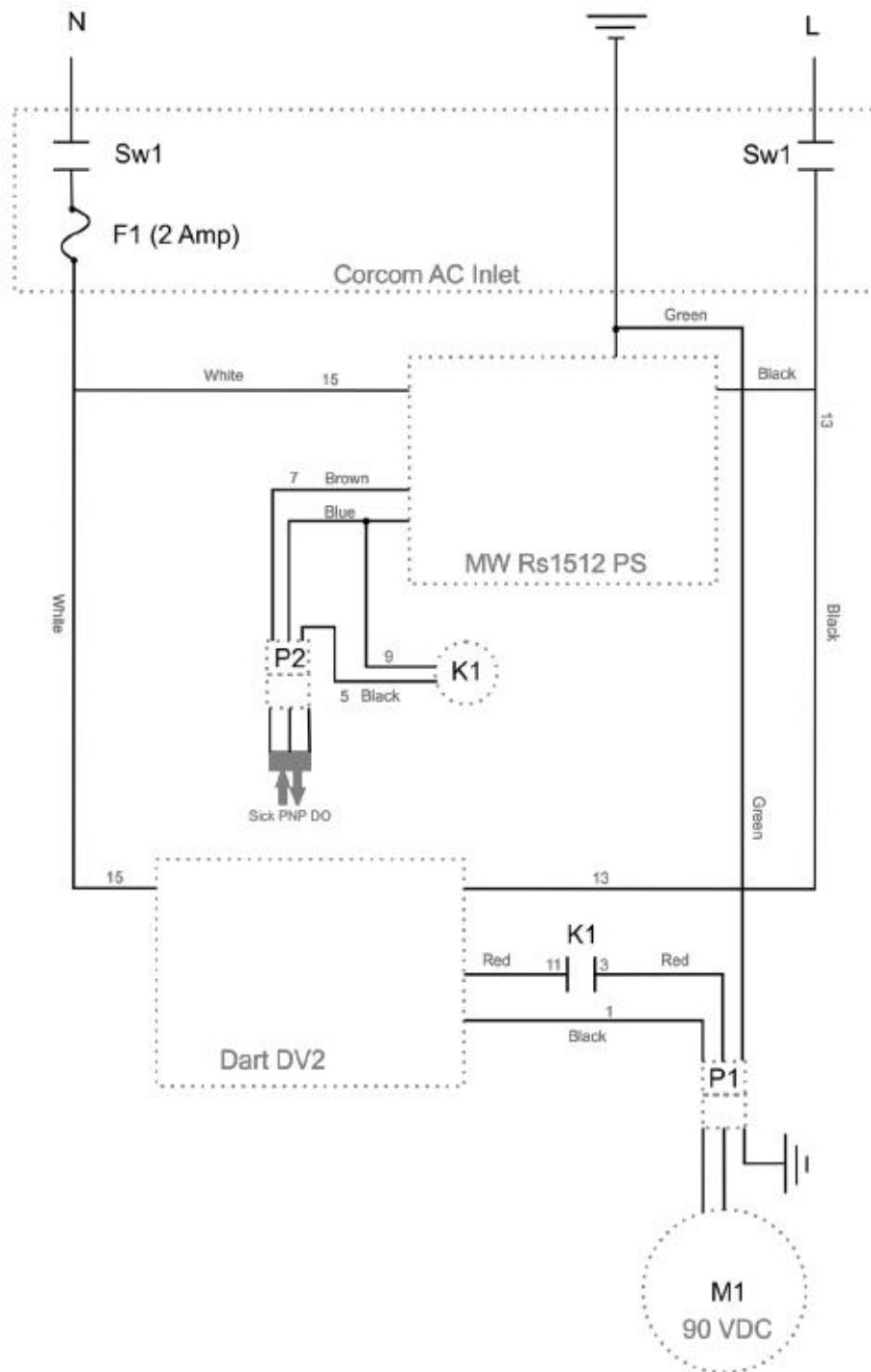

**RX-12c**

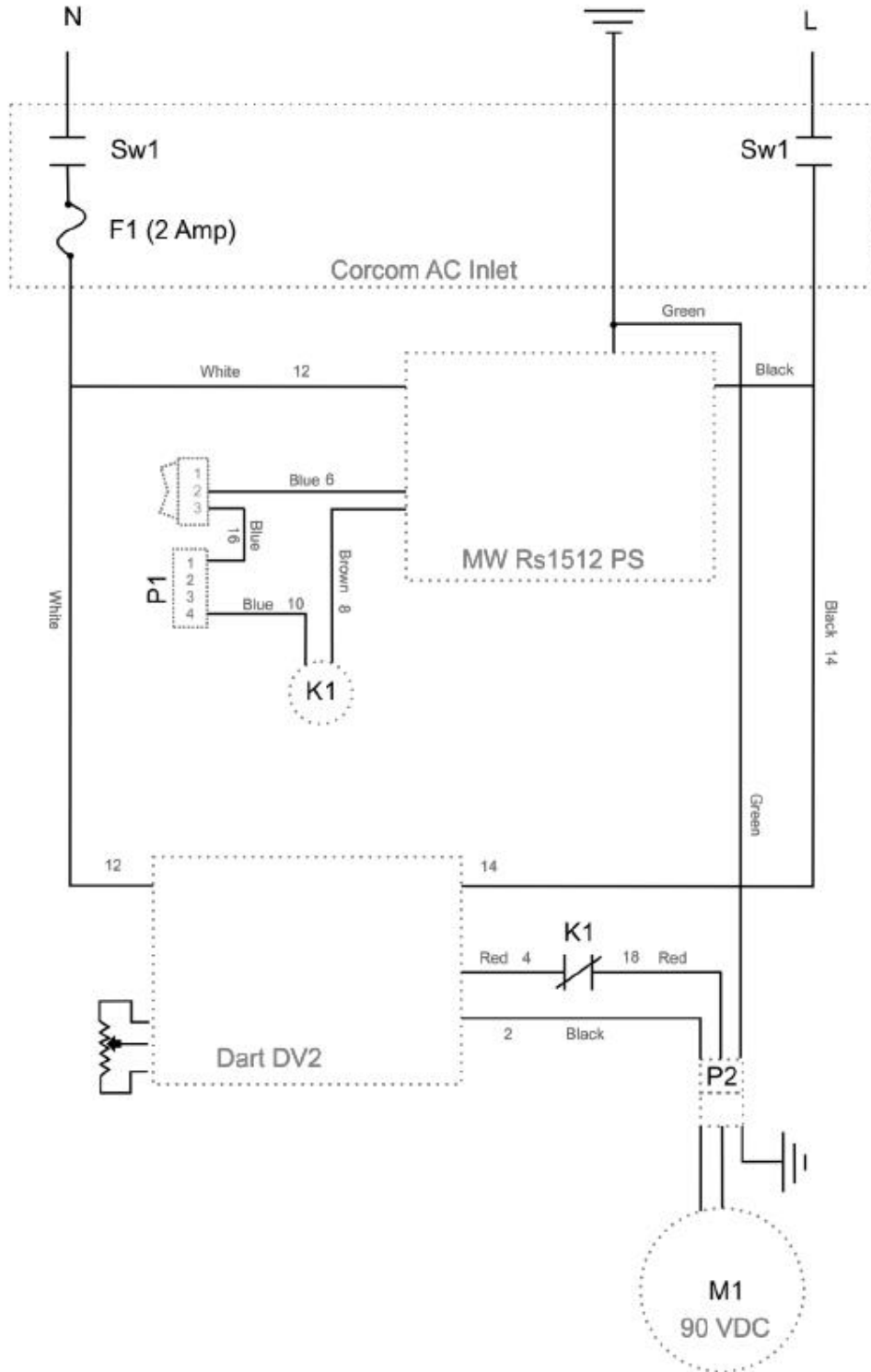

**RX-12cs**

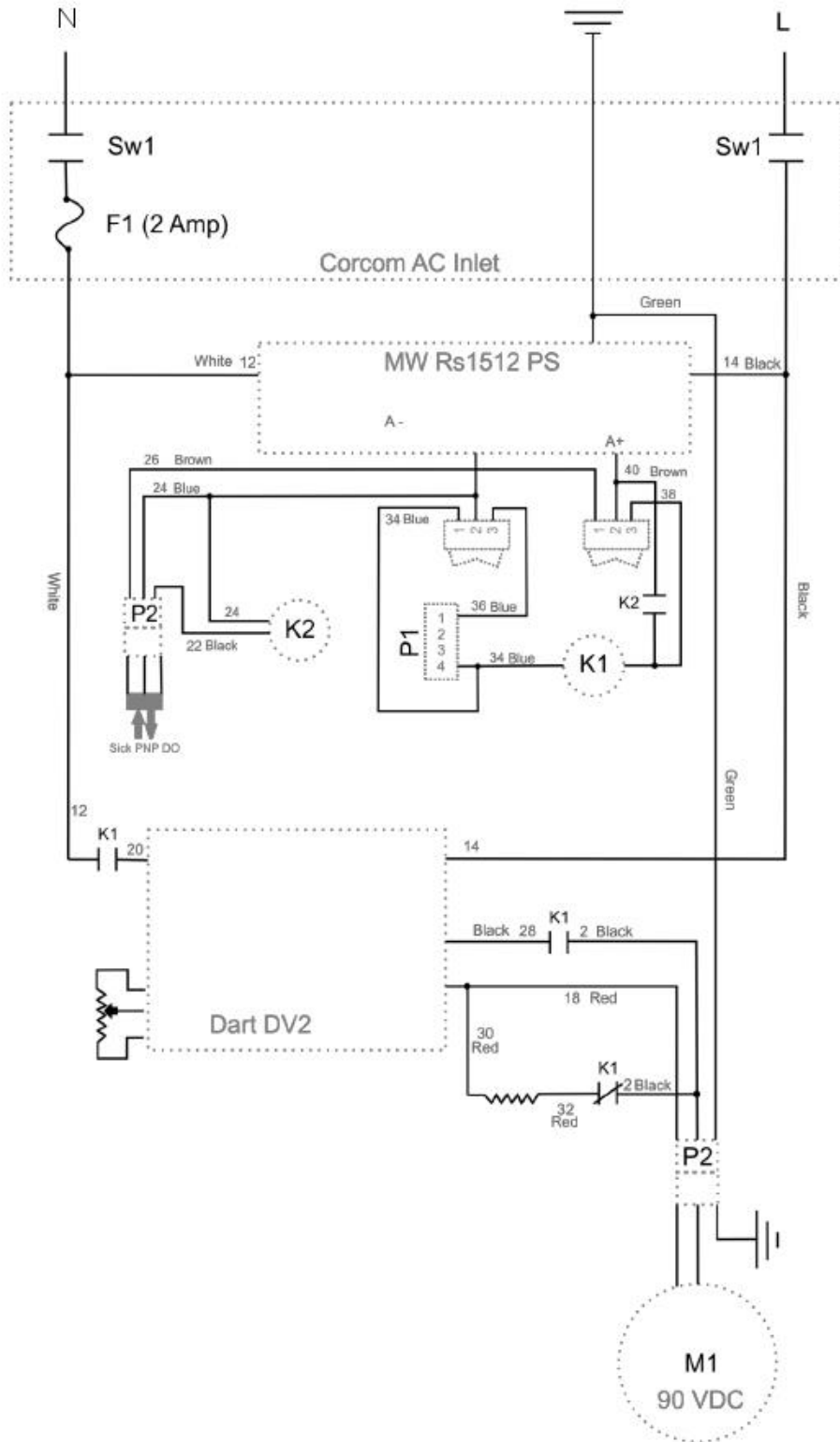

## ACCESSORIES AND AFTERMARKET OPTIONS



**Height Adjustable Mounting Stand.** Designed with locking swivel casters and low-toe profile for mobility on the production floor. 30"-40" height adjustable. Includes Stand Mounting Brackets when purchased with feeder.  
P/N 500020



**Spring Clips, set of 2.** Used on mailing inserters for a product pinch point.  
P/N G400185



**Resettable Piece Counter.** Keep an accurate count of pieces fed throughout the day, shift, job, or other variable, with push button reset. Counts up to 8-digits. Available for the RX-9s and RX-12cs.  
P/N G200503

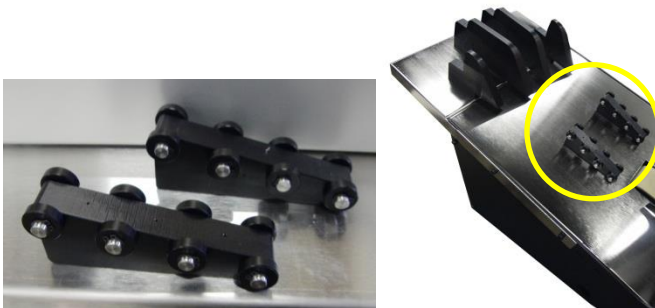

**Low-Profile Roller Support Wedges, set of 2.** Used to lift the weight heavy products off the feed belt to reduce friction and aid in product separation, and to provide added support/lift for long, flimsy products. Generally, products greater than 8" L.  
P/N G400200

## WARRANTY

### SUPERIOR-PHS LIMITED WARRANTY

Superior Paper Handling Solutions, Inc. (Superior-PHS) warrants this product to be free from defect in materials and workmanship, when used under recommended operating conditions, for a period of one year from the date of original shipment.

If you discover a defect during the warranty period, please notify the distributor from whom you purchased this product, who will arrange for the replacement parts to be sent to you. Defective parts must be returned to Superior-PHS for credit on replacement parts. Shipping and labor costs are not included in this warranty. If the defect is not field repairable and if you return it to Superior-PHS during the warranty period, Superior-PHS will, at its sole option, repair or replace this product at no charge to you other than shipping charges to and from the facility in Minneapolis, MN.

If you return this product to Superior-PHS for warranty repair or replacement, please attach to the returned product your name and your company's name, address, telephone number and fax number; a description of the problem; and a copy of the bill of sale or invoice that shows the appropriate serial number for the product. All returns must be accompanied by an authorized Superior-PHS Returned Goods Authorization (RGA) number. An authorized RGA number can be obtained from the Superior-PHS distributor from whom you purchased this product.

This warranty applied only to products manufactured by Superior-PHS. This warranty does not apply if the product has been damaged by accident, abuse, misuse, neglect, improper maintenance, misapplication, or as a result of being modified with the written permission of Superior-PHS; or if the product's serial number has been removed or defaced. This warranty further does not apply to the failure of any rubber-based or consumable components including, but not limited to, rollers, bearings, belts, fuses, or bulbs.

**ALL IMPLIED WARRANTIES INCLUDING WITHOUT LIMITATION THE IMPLIED WARRANTY OF FITNESS FOR A PARTICULAR PURPOSE AND THE IMPLIED WARRANTY OF MERCHANTABILITY ARE HEREBY DISCLAIMED.**

Superior-PHS is not responsible for special, incidental, or consequential damages resulting from any breach of warranty or under any other legal theory, including lost profits, downtime, goodwill, or damage to or replacement of equipment or property.

This warranty and the remedies set forth above are exclusive and are in lieu of all others, oral or written, express or implied. There are no warranties that extend beyond the description on the face hereof. No Superior-PHS employee, distributor, or agent is authorized to make any modification, extension, or addition to this warranty.



## NOTES

---

---

---

---

---

---

---

---

---

---

---

---

---

---

---

---

---

---

---

---

---

---

---

**Superior Paper Handling Solutions, Inc.**  
7150 Boone Avenue North, Suite 130  
Brooklyn Park, MN 55428

Tel: 763-546-9140  
Fax: 763-546-8883  
Email: [info@superior-phs.com](mailto:info@superior-phs.com)  
Web: [www.Superior-PHS.com](http://www.Superior-PHS.com)